

 **STOVAX**

STUDIO
air



Installation Instructions
Instructions d'installation
Istruzioni per l'Installazione

CONTENTS/ CONTENU/ CONTENUTO

Freestanding Stove Range Gamme de poêle Caminetti da libero appoggio

Covering the following models:
Couvrant les modèles suivants:
Per i seguenti modelli:

Studio Air 1	726-175
Studio Air 2	726-181

GB

Appliance Commissioning Sheet	3
Installation Instructions	6
Dimensions.....	7
Distance to Combustibles.....	8
Parts Identifier.....	10
Essential Information.....	11
Pre-Installation.....	12
Installing the Appliance.....	15
Reversing The Door.....	18
Commissioning	22
Maintenance & Servicing	23
Information Requirement - Solid Fuel.....	26
Spare Parts List	69
Service Records	71

FR

Liste Des Vérifications De Mise En Service	4
Instructions D'installation	27
Dimensions.....	28
Distance Des Matériaux Combustible.....	29
Identificateur De Pièces.....	31
Informations Essentielles.....	32
Instructions Avant L'installation.....	33
Installation D'appareil.....	36
Inversion De La Porte.....	39
Mise En Service	43
Maintenance Et Révision	44
Fiche produit - Informations à fournir pour un appareil de chauffage localisé à combustible solide.....	47
Liste Des Principales Pièces De Rechange	69
Fiches De Maintenance	71

IT

Elenco Di Controllo Per La Messa A Punto Dell'apparecchio	5
Istruzioni per l'Installazione	48
Dimensioni.....	49
Distanze Da Materiali Combustibili.....	50
Numero Identificativo Delle Parti.....	52
Informazioni importanti.....	53
Pre-Installazione.....	54
Installazione.....	57
Inversione Dello Sportello.....	60
Messa A Punto.....	64
Manutenzione E Interventi Di Assistenza	65
Scheda del prodotto: richiesta di informazioni per riscaldatore combustibile solido per ambienti.....	68
Elenco Delle Parti Di Ricambio ..	69
Registri Degli Interventi Di Assistenza	71

APPLIANCE COMMISSIONING SHEET

To assist us in any guarantee claim please complete the following information:-

Dealer appliance was purchased from:

Name:

Address:

Telephone number:

Essential information - MUST be completed:

Date Installed:

Model Description:

Serial Number:

Installation Engineer:

Company Name:

Address:

Telephone number:

Commissioning Checks - to be completed and signed:

Is flue system correct for the appliance:	YES <input type="checkbox"/>	NO <input type="checkbox"/>
Flue swept and soundness test complete:	YES <input type="checkbox"/>	NO <input type="checkbox"/>
Smoke test completed on installed appliance	YES <input type="checkbox"/>	NO <input type="checkbox"/>
Spillage test completed	YES <input type="checkbox"/>	NO <input type="checkbox"/>
Use of appliance and operation of controls explained	YES <input type="checkbox"/>	NO <input type="checkbox"/>
Clearance to combustible materials checked	YES <input type="checkbox"/>	NO <input type="checkbox"/>
Instruction book handed to customer	YES <input type="checkbox"/>	NO <input type="checkbox"/>
CO Alarm Fitted	YES <input type="checkbox"/>	NO <input type="checkbox"/>
Flue draught Reading (Pa)	HOT <input type="text"/>	COLD <input type="text"/>

Signature: Print Name:

LISTE DES VÉRIFICATIONS DE MISE EN SERVICE

Pour faciliter les démarches de dédommagement sous garantie, veuillez fournir les informations suivantes :-

Distributeur où l'appareil a été acheté

Nom :

Adresse :

Numéro de téléphone :

Informations essentielles – Cette section DOIT être remplie:

Date d'installation :

Description du modèle :

Numéro de série :

Technicien installateur:

Nom de la société :

Adresse :

Numéro de téléphone :

Vérifications de mise en service - à remplir et signer:

Le conduit de fumée est approprié à cet appareil	OUI <input type="checkbox"/>	NO <input type="checkbox"/>
Le conduit a été ramoné et le test de vacuité a été effectué.	OUI <input type="checkbox"/>	NO <input type="checkbox"/>
Le test de fumée de l'appareil installé a été effectué	OUI <input type="checkbox"/>	NO <input type="checkbox"/>
Le test d'étanchéité du corps de chauffe a été effectué	OUI <input type="checkbox"/>	NO <input type="checkbox"/>
L'utilisation de l'appareil et le fonctionnement des commandes ont été expliqués	OUI <input type="checkbox"/>	NO <input type="checkbox"/>
Les distances aux matériaux combustibles ont été vérifiées	OUI <input type="checkbox"/>	NO <input type="checkbox"/>
Le manuel d'instructions a été remis au client	OUI <input type="checkbox"/>	NO <input type="checkbox"/>
Le détecteur-avertisseur de CO a été installé (recommandé)	OUI <input type="checkbox"/>	NO <input type="checkbox"/>
Lecture du tirage du conduit (Pa)	CHAUD <input type="text"/>	FROID <input type="text"/>

Signature:

Nom en majuscules:

ELENCO DI CONTROLLO PER LA MESSA A PUNTO DELL'APPARECCHIO

La compilazione del modulo seguente sarà utile in caso di interventi in garanzia.

L'apparecchio è stato acquistato presso:

Nome:

Indirizzo:

Numero di telefono:

Dati obbligatori – DEVONO essere inseriti:

Data di installazione:

Descrizione del modello:

Numero di serie:

Tecnico installatore:

Nome azienda:

Indirizzo:

Numero di telefono:

Controlli di messa a punto (da compilare e firmare):

Il sistema della canna fumaria è adatto all'apparecchio:	Sì <input type="checkbox"/>	NO <input type="checkbox"/>
Controllo della pulizia e dello stato della canna fumaria completato:	Sì <input type="checkbox"/>	NO <input type="checkbox"/>
Controllo fumi sull'apparecchio installato completato:	Sì <input type="checkbox"/>	NO <input type="checkbox"/>
Controllo versamenti completato:	Sì <input type="checkbox"/>	NO <input type="checkbox"/>
Utilizzo dell'apparecchio e svolgimento dei controlli spiegati:	Sì <input type="checkbox"/>	NO <input type="checkbox"/>
Spazio libero dai materiali combustibili controllato:	Sì <input type="checkbox"/>	NO <input type="checkbox"/>
Manuale di istruzioni consegnato al cliente	Sì <input type="checkbox"/>	NO <input type="checkbox"/>
Allarme di monossido di carbonio installato	Sì <input type="checkbox"/>	NO <input type="checkbox"/>
Letture del tiraggio del canale da fumo (Pa)	CALDO <input type="text"/>	FREDDO <input type="text"/>

Nome in stampatello: Firma:.....

GENERAL INFORMATION

Installing the Appliance

Each installation is unique to the property so it is not possible to give details to suit every setting.

The installation must comply with Building Regulations and be made using "best practice" construction methods.

Take care when installing the appliance. Careless handling and use of tools can damage the finish and/or area.

Appliance Location

Many fireplace openings have a supporting lintel. Do not remove without supporting the remaining structure of the building. Do not support the structure with the appliance or the flue system.

If installing with a Dedicated External Air Kit, please consult manual PM1690 prior to installation

Registered Professional:

Before installation and/or use of this appliance please read these instructions fully and carefully to ensure that you have fully understood their requirements.

The appliance must be fitted by a registered installer, or approved by your local building control officer.

Structural Support:

If installing on a wooden floor check that the floor joists are strong enough to bear the weight of the insert, chimney and construction parts.

Hearth:

A Constructional Hearth with a depth of 125mm and a 12mm. Decorative Hearth Plate must be installed to protect a combustible floor from the risk of falling embers if mounted directly on the floor. The Decorative Hearth must extend 300mm in front of the hearth and can be made of natural stone, concrete, metal or glass.

Final inspection of the installation:

When it has been installed, the appliance must be commissioned in accordance with standards and practices to ensure full working order and a correct handover given to the customer.

Flue and Chimney

The flue or chimney system must be able to withstand flue temperatures of up to 400°C.

The external diameter of the connection sleeve is 155mm.

In normal operating mode, draft in the chimney should be 20-25 Pa close to the connection sleeve. The draft is affected primarily by the length and area of the chimney and also by how well sealed it is.

The minimum recommended chimney length is 3.5m and a suitable cross-section area is 150-200cm² (140-160 mm in diameter).

Sharp bends and horizontal lengths in a flue pipe reduce the draft in the chimney.

It must be possible to sweep the full length of the flue, and the soot doors must be easily accessible.

Carefully check that the chimney is sealed and that there is no leakage of smoke from the connections.

Combustion Air Supply

When the appliance is installed, it is essential to ensure adequate air is supplied to the room. Air can be provided indirectly via a vent in the outer wall or via a duct from the outside that connects to the sleeve on the underside of the insert. The required volume of combustion air is about 20 m³/hour.

The outer diameter of the combustion air connection sleeve is 80mm. If a pipe is longer than 1 m, its diameter must be increased to 100mm and a larger wall vent will be required.

In heated spaces, the flue must be insulated to prevent condensation using 30mm mineral wool covered with a vapour barrier. The hole in the wall (or floor) at the exit point must be properly sealed with flue jointing compound.

A flexible pipe to provide external directly into the appliance is available and must be fitted at the time of installation.

CO Alarms

Building regulations require that whenever a new or replacement fixed solid fuel or wood/biomass appliance is installed in a dwelling a carbon monoxide alarm, complying with BS EN50291, must be fitted in the same room as the appliance.

HETAS recommend the unit is permanently fixed in accordance with the manufacturer's installation instructions or with the guidance contained in Approved Document J where no other information is available.

Provision of an alarm must not be considered a substitute for either installing the appliance correctly or ensuring regular servicing and maintenance of the appliance and chimney system.

DIMENSIONS

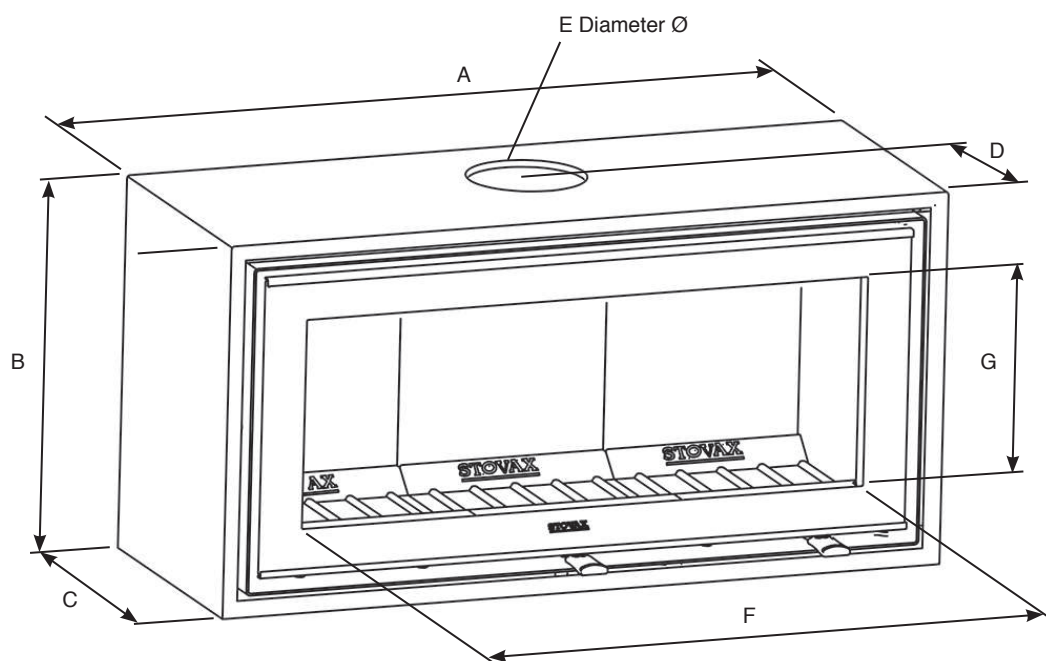

	A	B	C	D	E	F	G
Studio Air 1	809	481	382	234	152	590	259
Studio Air 2	1009	506	382	234	152	790	284

All dimensions in mm. (25.4 mm = 1")

EXTERNAL AIR

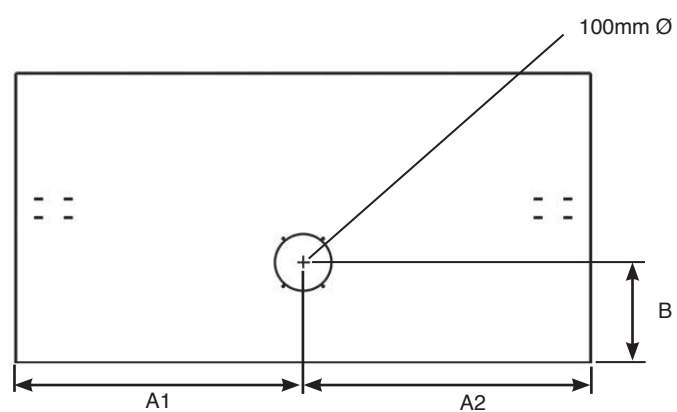

	A1	A2	B
Studio Air 1	404.5	404.5	174.5
Studio Air 2	504.5	504.5	174.5

CLEARANCE TO COMBUSTIBLE MATERIAL

ENCLOSED SETTING

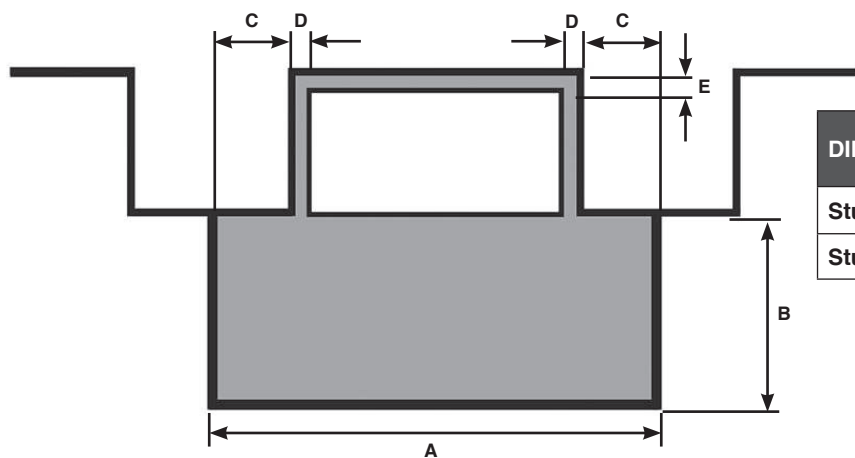

DIMENSIONS (MM)	A	B	C	D	E
Studio Air 1	1309	500	250	50	125
Studio Air 2	1609	700	300	50	125

OPEN SETTING

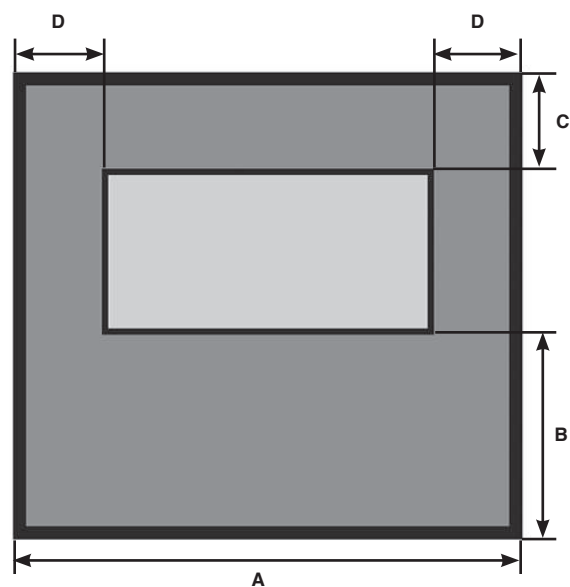

DIMENSIONS (MM)	A	B	C	D
Studio Air 1	1309	500	125	150
Studio Air 2	1609	700	125	180

HEIGHT TO MANTLE

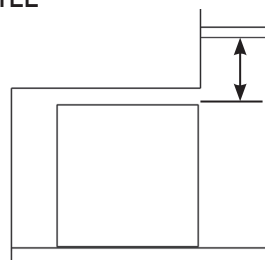

DIMENSIONS (MM)	HEIGHT
Studio Air 1	500
Studio Air 2	800

HEARTH THICKNESS

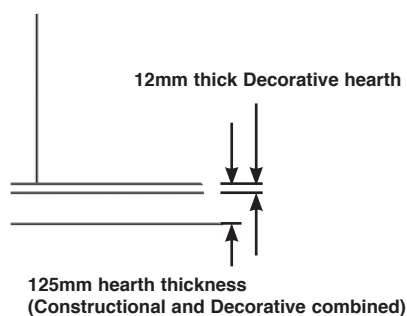

If this appliance is installed on a Stovax Bench, the bench may stand on a 12mm thick non-combustible hearth and it is recommended that the 225mm hearth depth should be increased to safely contain any falling logs or embers.



*Stovax recommends that the depth of the Decorative Hearth is equal to or greater than the height of the appliance from the floor, OR, the length of the door from the wall when in the open position.
USE WHICHEVER FIGURE IS GREATER.

CLEARANCE TO NON-COMBUSTIBLE MATERIAL

PARALLEL POSITION CLEARANCES

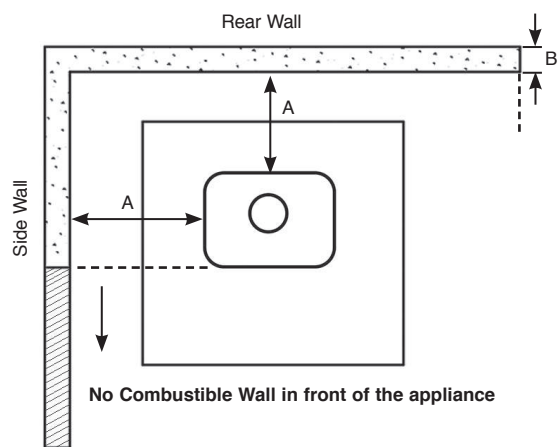

Height above appliance

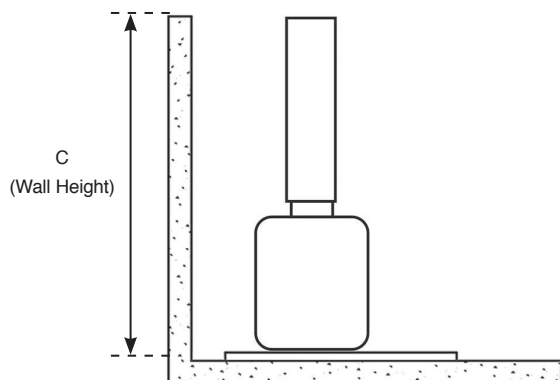

CORNER POSITION CLEARANCES

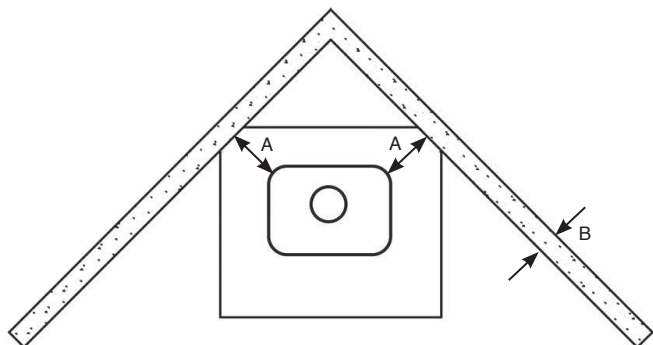

HEARTH THICKNESS

This appliance must stand on a non-combustible constructional hearth which is at least 125mm thick

DISTANCE TO NON-COMBUSTIBLE MATERIALS		
Distance of Appliance to Wall (A)	Minimum Thickness of wall (B)	Minimum Height of Wall (C)
0mm - 50mm	200mm	Height of appliance + 300mm OR 1200mm from the hearth (take largest dimension)
51mm - 300mm	75mm	
300mm+	No requirement	No requirement

PARTS IDENTIFIER

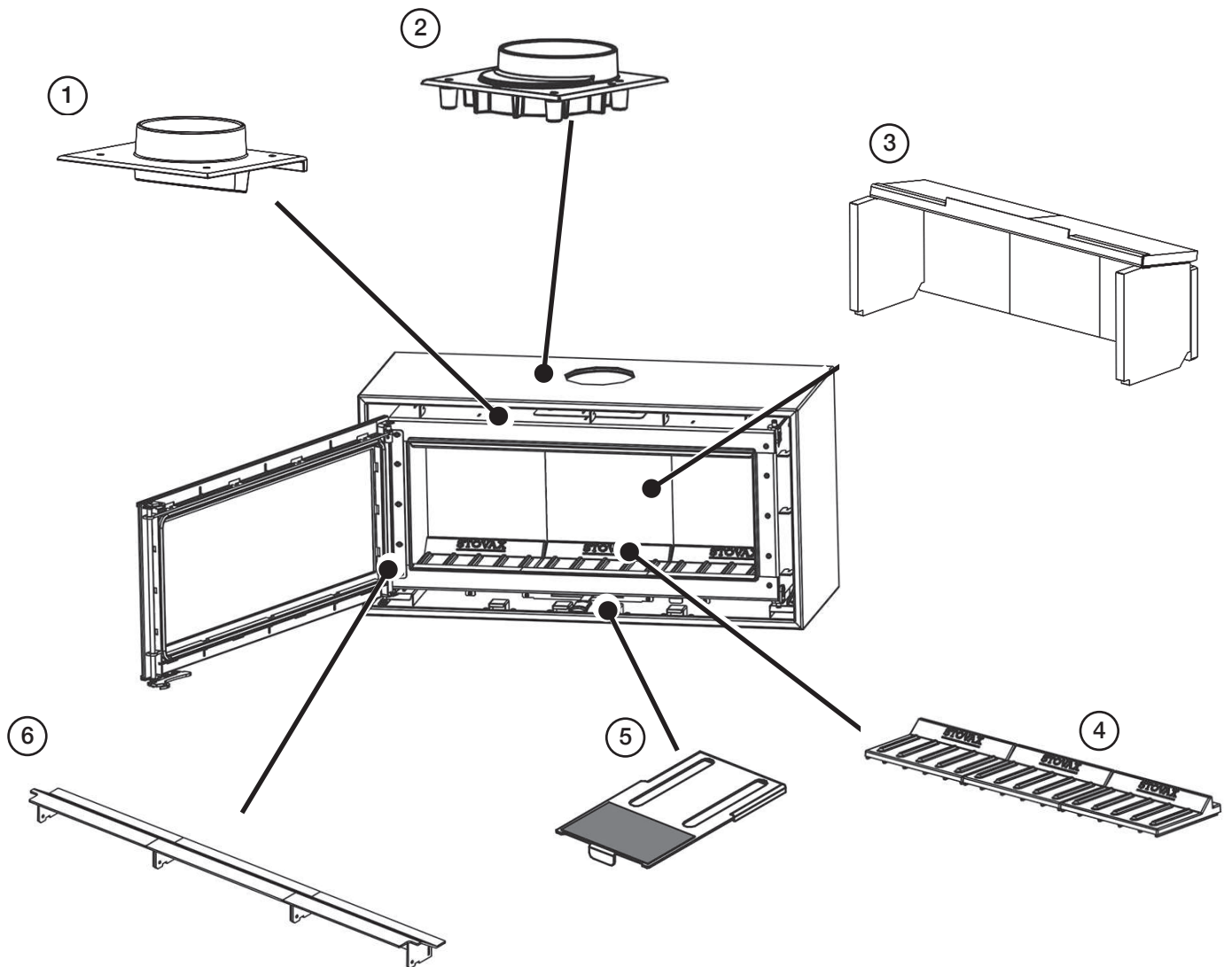

1. Inner Flue Collar
2. Top Flue Collar
3. Brick Liners and Baffle Set
4. Base Bricks
5. Dataplate
6. Log Guard

ESSENTIAL INFORMATION

GENERAL	Model:			Studio Air 1	Studio Air 2
	Nominal Heat Output	Wood	kW	5.0	8.2
	Efficiency	Wood	%	79.6	78.5
	CO @ 13% O ₂	Wood	%	0.12	0.08
	Weight		Kg	123	165
Recommended Fuels	Wood	Seasoned Wood (less than 20% moisture content)			

As tested to the requirements of EN 13229 for intermittent operation

FLUES	Flue/Chimney Size	With Liner of Factory made system (diameter) installed in accordance with manufacturers instructions	mm	153	153
			inch	6	6
	Flue/Chimney minimum height	All products	m	4.5	4.5
			feet	15	15
	Flue Draught	Min	Pa	10	10
		Nominal		12	12
		Max		20	20
	Flue Gas Mass Flow	Wood	g/s	4.7	6.5
	Average Flue Gas Temperature	Wood	°C	261	304
	Flue Outlet Size (Top Option)		mm	153	153
inch			6	6	

European Min Spec for Solid Fuel Chimney Flue - T400 N2 D 3 G50

VENTILATION	A) Traditionally Built Homes • Where leakage is greater than 5m ³ /hour/m ² . • Ventilation normally required = 550mm ² per kW output over 5kW		B) Modern Construction Homes • Where leakage is less than 5m ³ /hour/m ² . • Ventilation normally required = 550mm ² per kW		
	A	Additional Ventilation	mm ²	None	1760
			cm ²	None	17.6
			in ²	None	2.84
	B	Additional Ventilation	mm ²	2750	4510
			cm ²	27.5	45.10
in ²			4.44	7.28	

PRE-INSTALLATION

To make the installation of the appliance easier it is best to remove the internal components before fitting into the builders opening/studwork.

DOOR

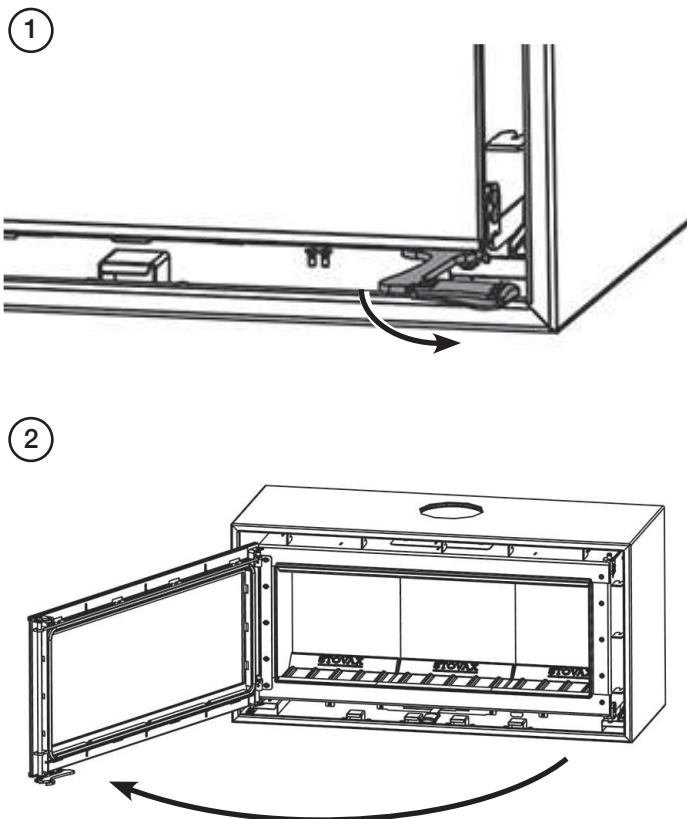

LOG GUARDS

Do not use appliance without the log guards in position.

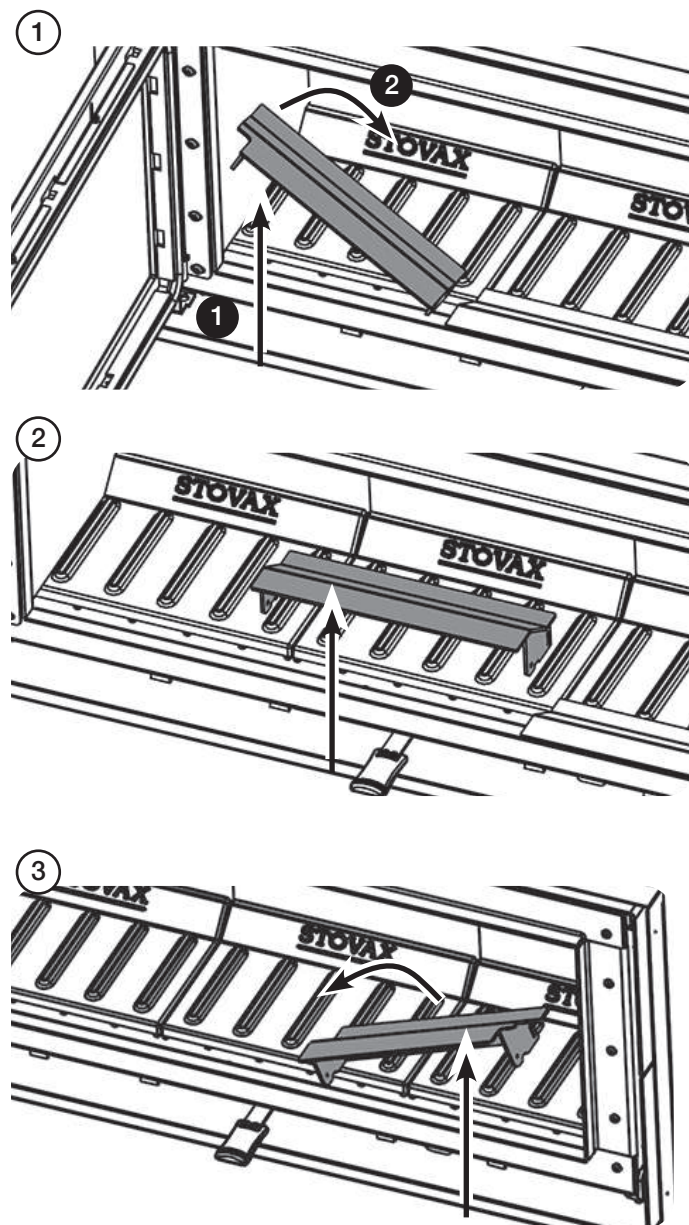

i The left and right log guards are handed. The cutouts must be positioned to the side of the firebox facing forward.



FIREBRICKS & BAFFLE

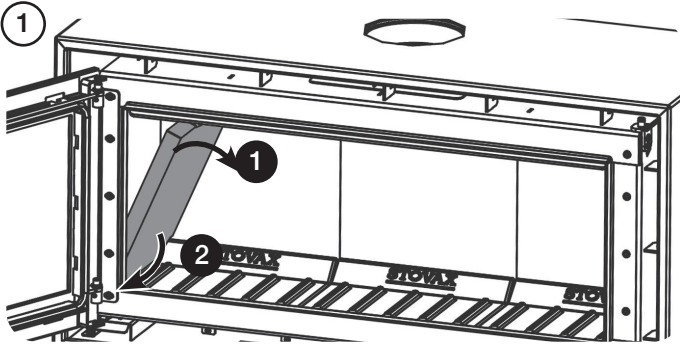

Support Baffle Bar

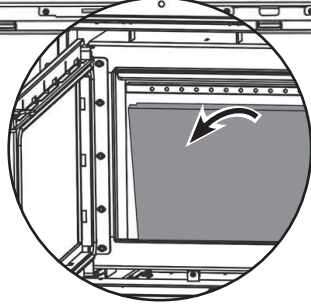
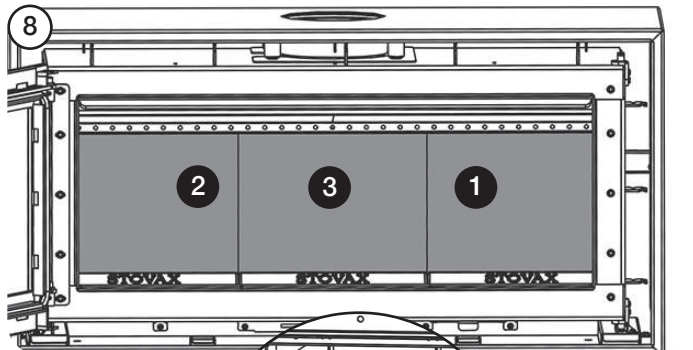
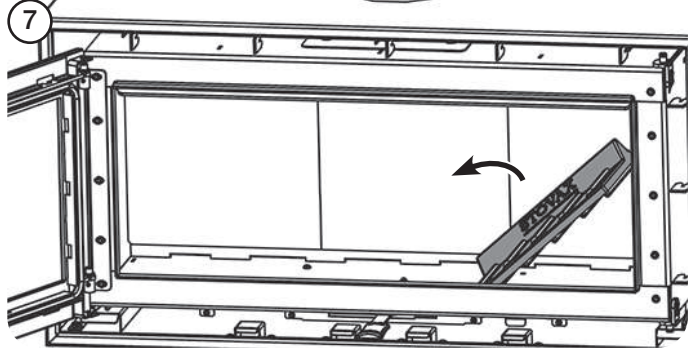
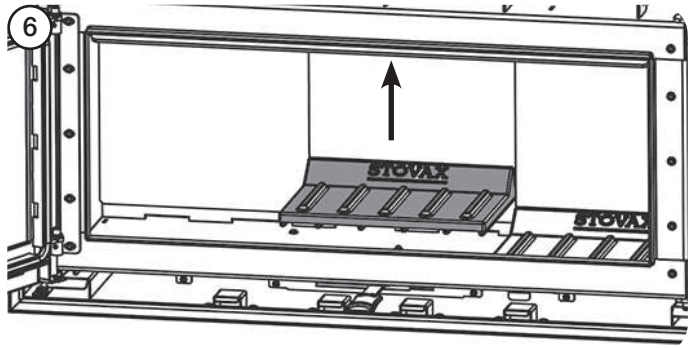
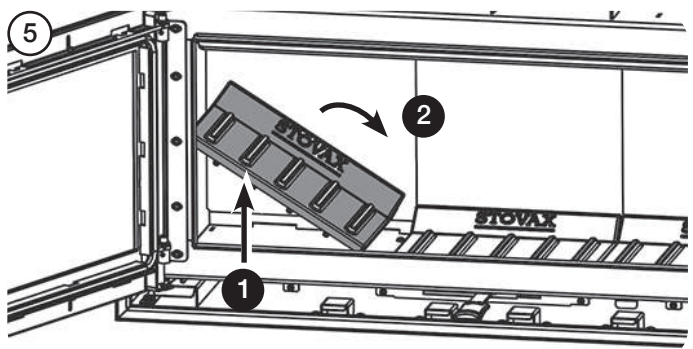
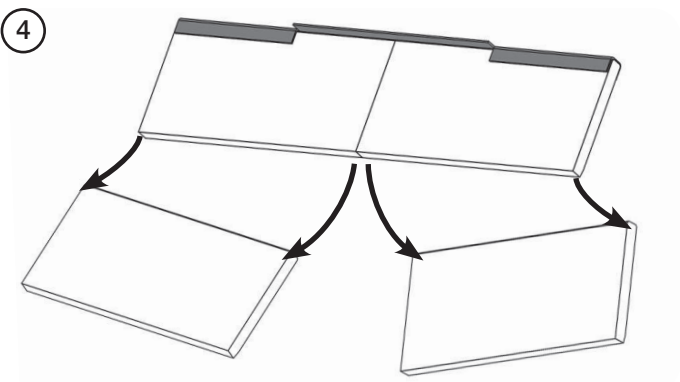
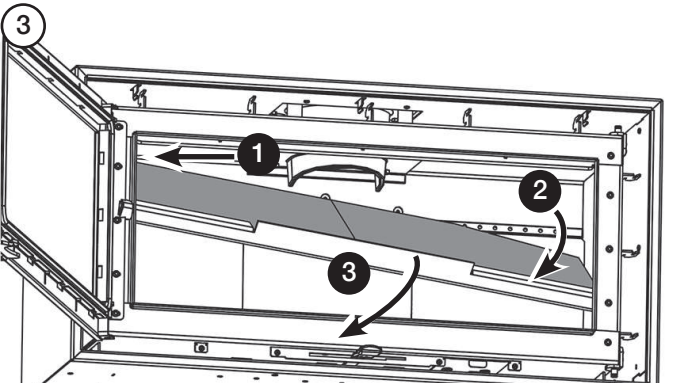
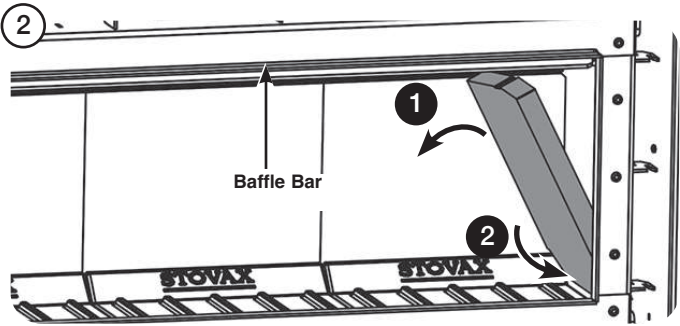

INNER COLLAR

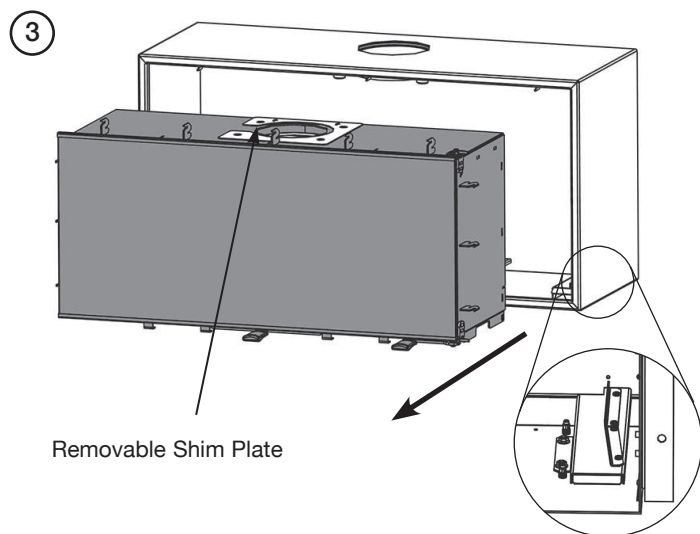
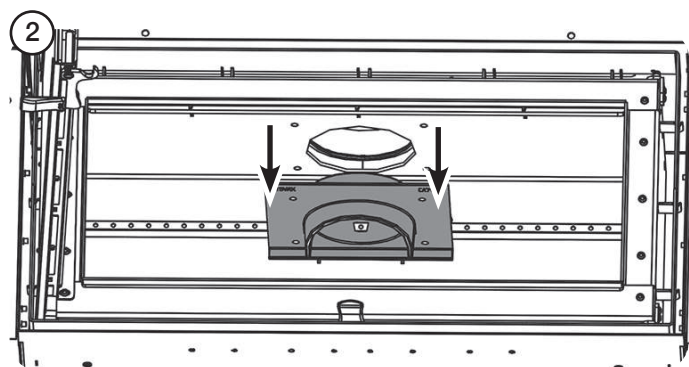
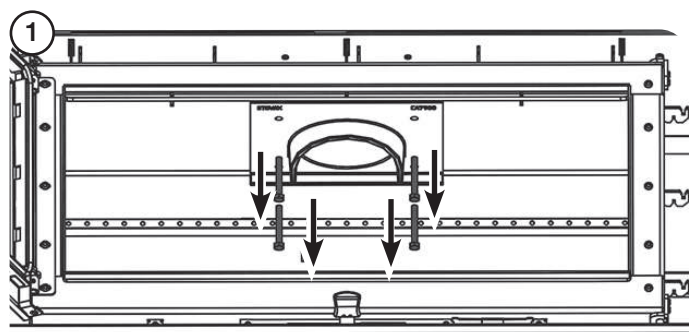

REMOVAL OF OUTER COLLAR

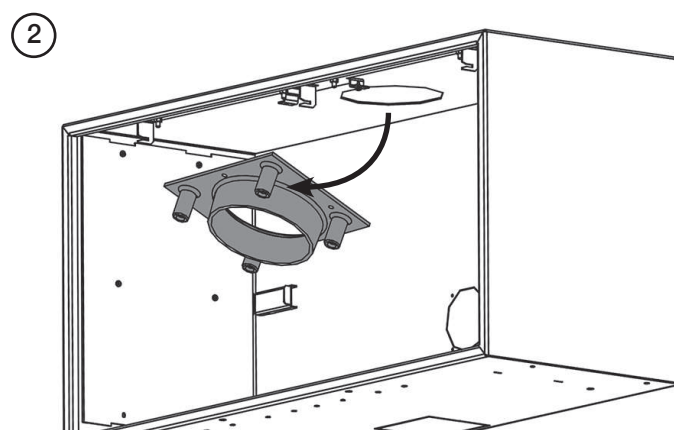
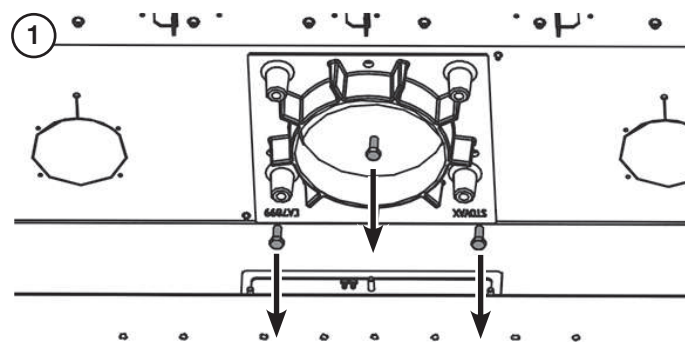
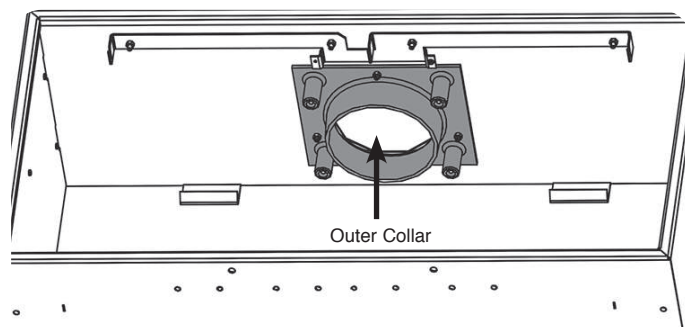

The bolts locate in a bracket in top of the outer box. This remains in place when installing the flue system.

INSTALLATION

INSTALLING THE APPLIANCE

Each installation is unique to the property so it is not possible to give details to suit every setting. The installation must comply with Building Regulations and be made using "best practice" construction methods.

Many fireplace openings have a supporting lintel. Do not remove without supporting the remaining structure of the building. **Do not support the structure with the appliance or the flue system.**

Take care when installing the appliance. Careless handling and use of tools can damage the finish and/or area.

i **NOTE:** If installing with a Dedicated External Air Kit, please consult manual PM1690 prior to installation.

OPTIONAL EXTRAS

The following optional extras can improve the performance of the appliance and need to be fitted at the time of installation.

DECORATIVE FLUE COVER

This appliance can be fitted with an optional decorative flue cover. For installation procedures please refer to the instructions supplied with the kit.

DEDICATED EXTERNAL AIR KIT

This appliance can be fitted with an optional kit to help bring air directly into the appliance from outside. For installation and operating procedures, refer to the instructions supplied with the Outside Air kit.

BENCH

This appliance can be mounted on Stovax Bench. For installation refer to the instructions supplied with the Bench.

INSTALLATION

Take care when installing the appliance. Careless handling and use of tools can damage the finish and/or area.

BOLTING THE APPLIANCE TO THE HEARTH

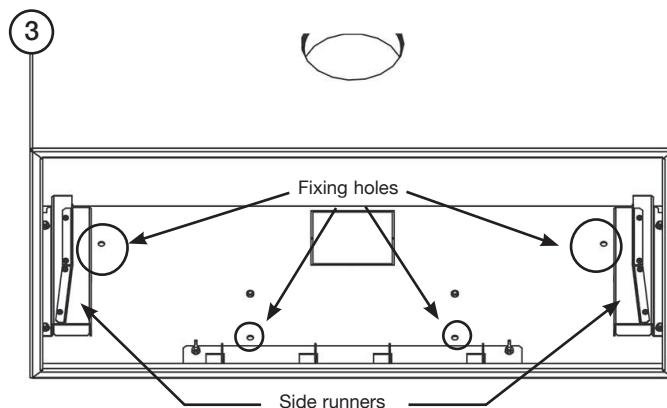
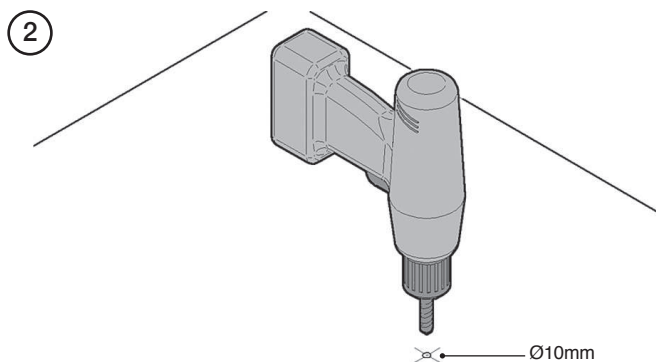
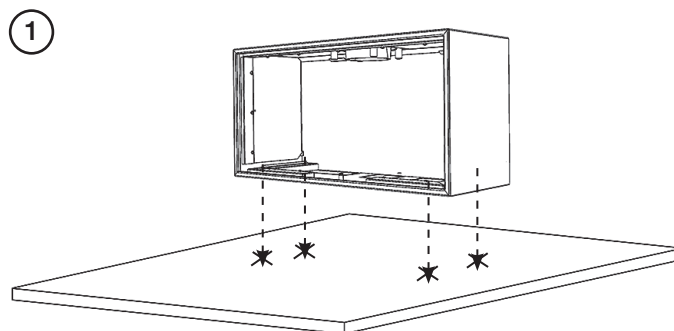

The outer box can only be refitted with the Air Slider in the central position.

REFITTING THE FLUE COLLARS

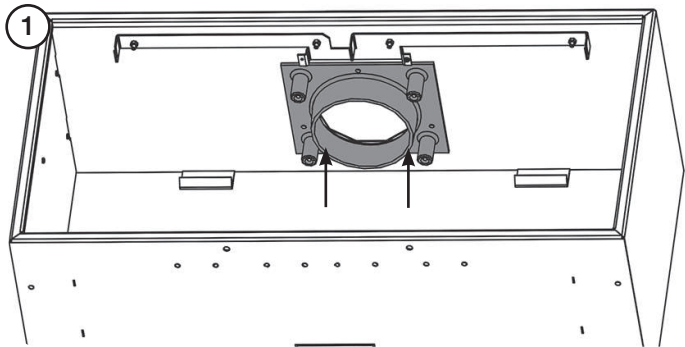

Loosely fit short bolts (1) then fit longer bolts (2).

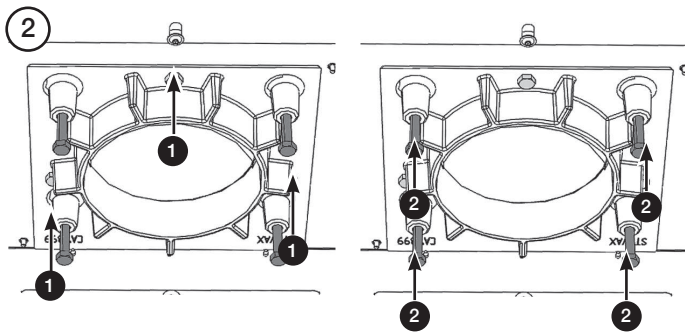

Tighten short bolts.

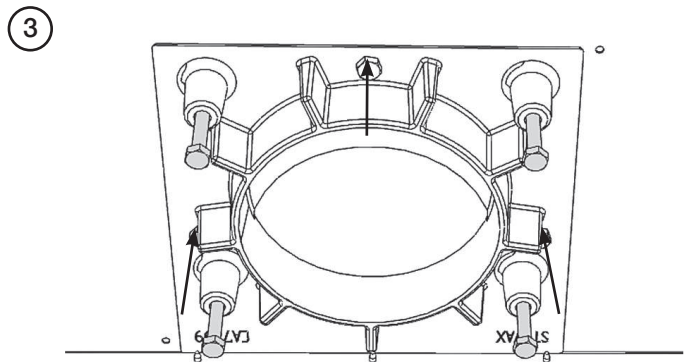

Remove longer bolts.

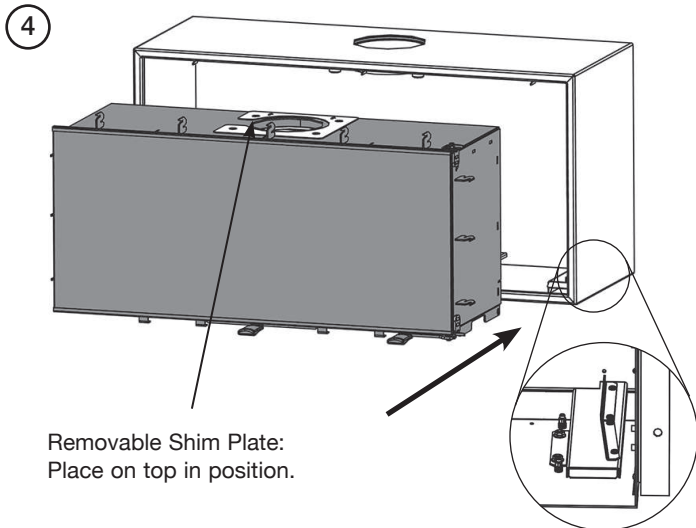

Removable Shim Plate:
Place on top in position.

5

Inner Flue Collar

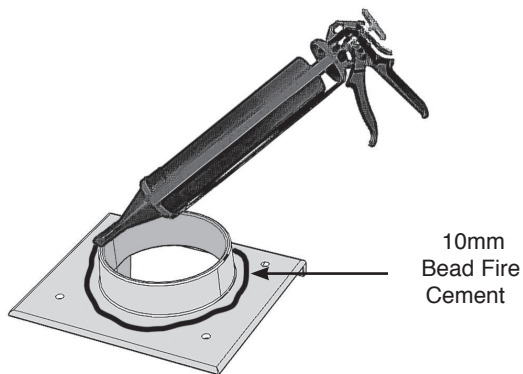

10mm
Bead Fire
Cement

6

Inner box removed for clarity

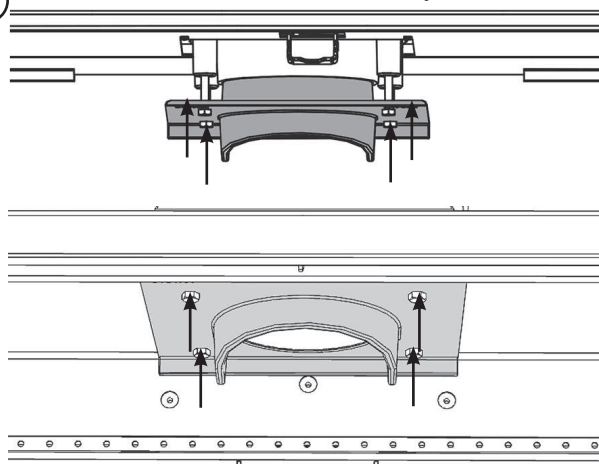

REFITTING FIREBRICKS

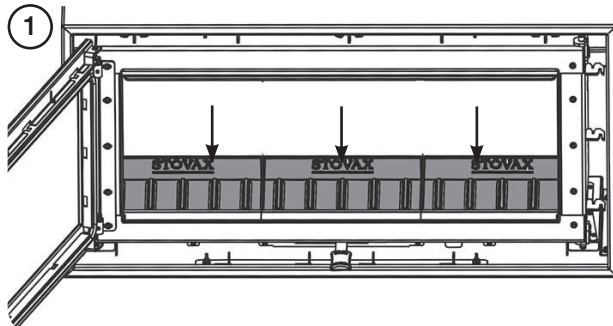

2

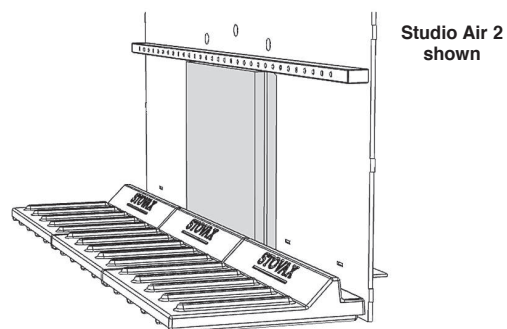

Studio Air 2
shown

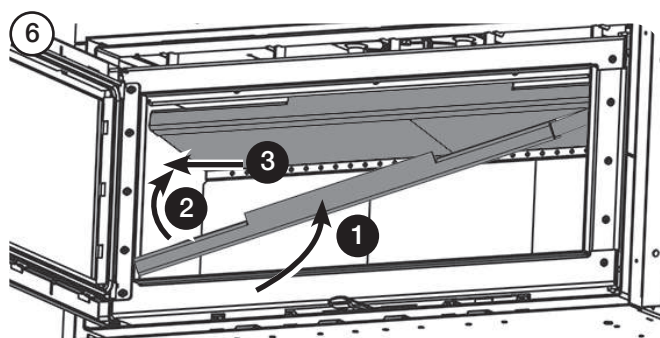
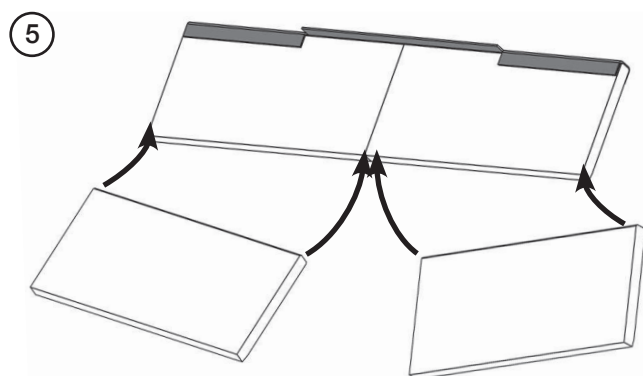
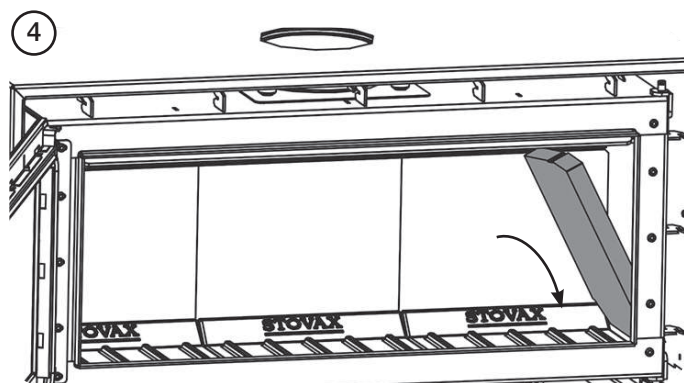
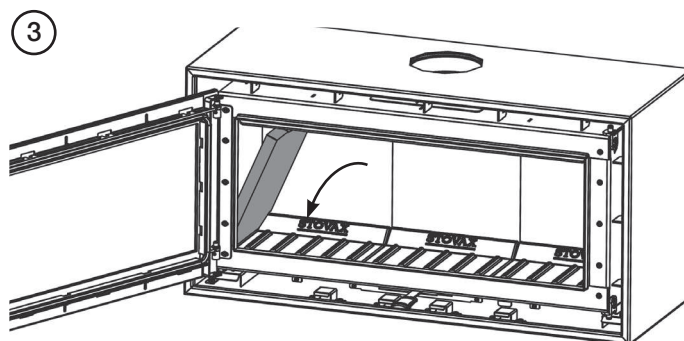
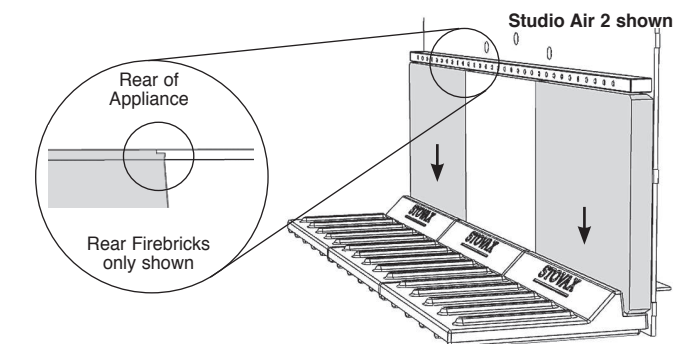

FITTING THE INNER DECORATIVE FRAME

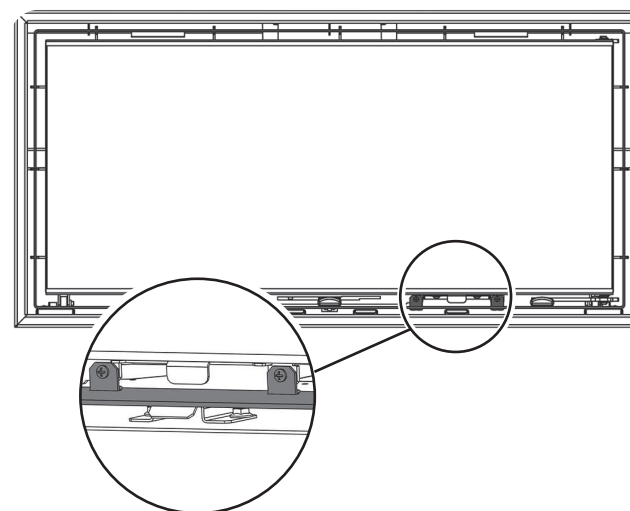
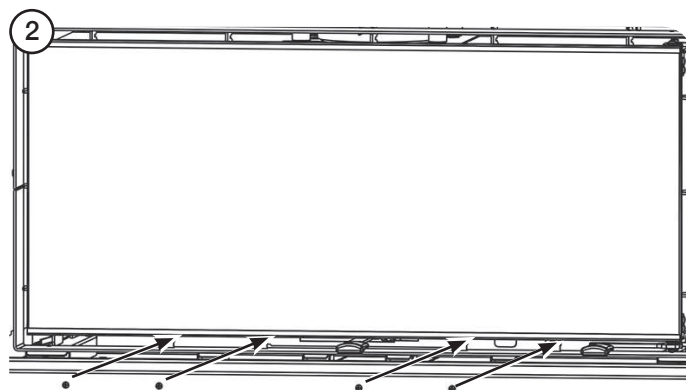
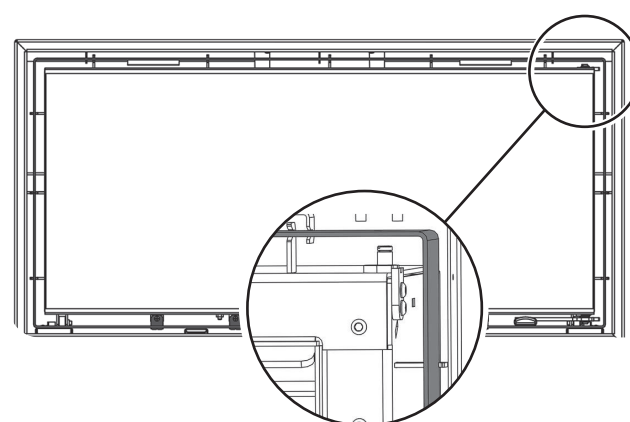
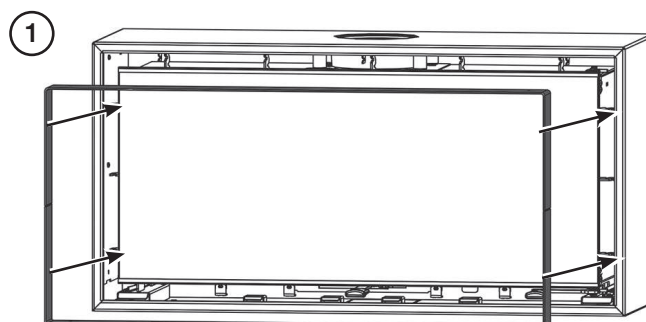

REVERSING THE DOOR

i Note: In order to change the door orientation the existing door latch will need to be replaced with a Reversible Door Handle Latch: Stovax Part No. 326-929. Retain original Latch to return the door to its original state.

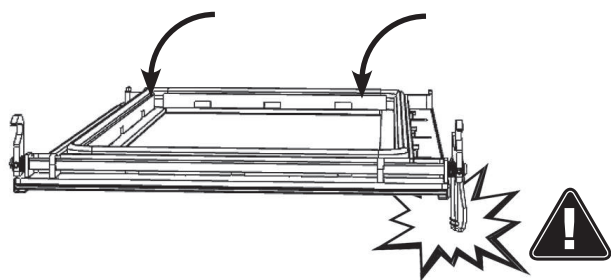
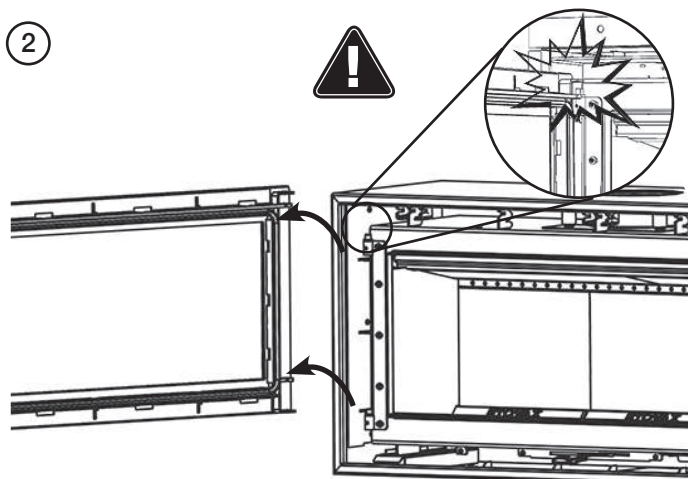
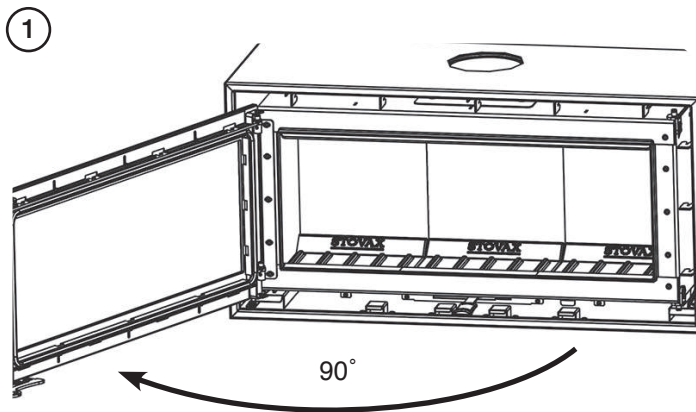

i After reversing the door it may be necessary to adjust the door hinges and catches to ensure the safe, correct closing of the door. The door must be horizontal/level with the top of the inner box and the door catch engages correctly. See Maintenance & Servicing.

Hinge Assembly

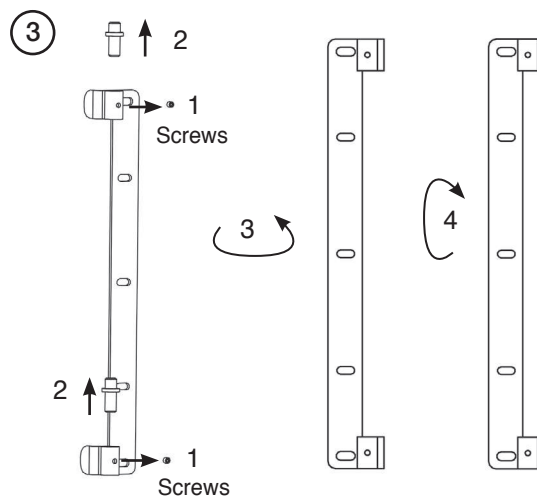
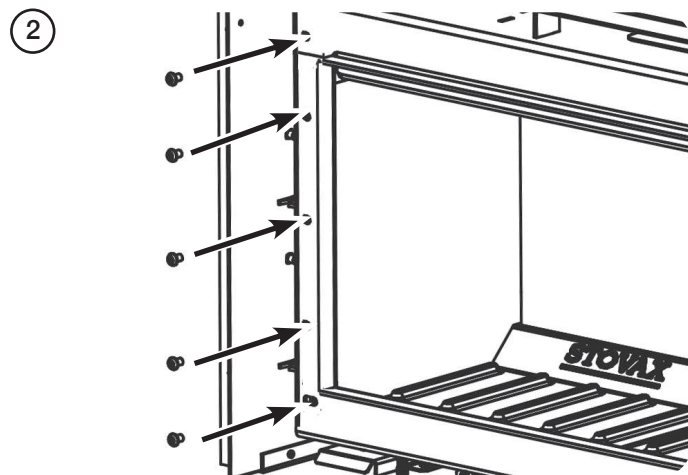
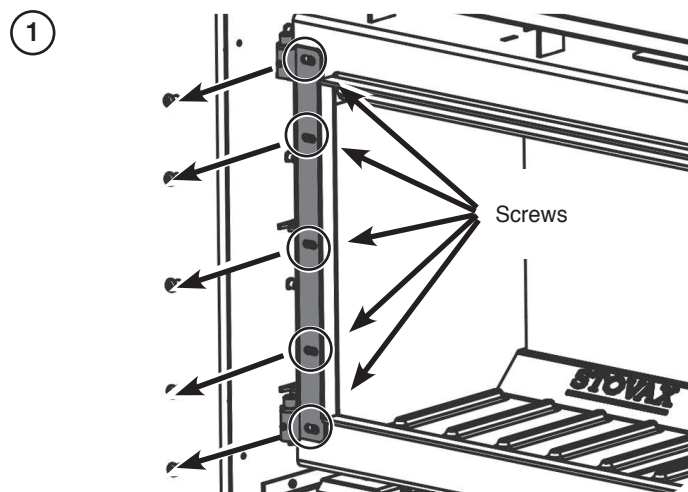

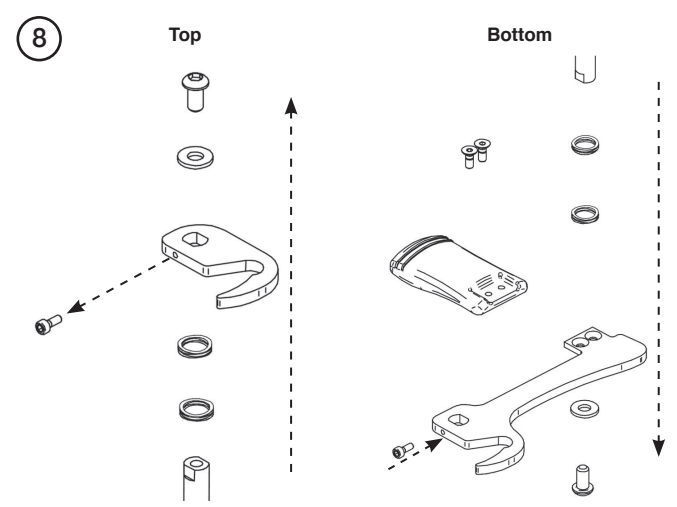
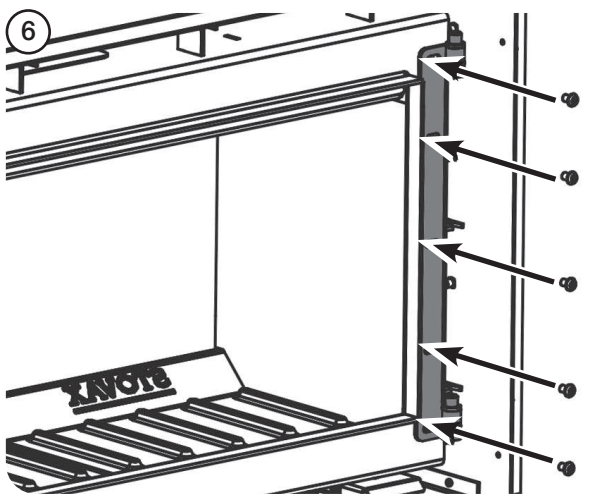
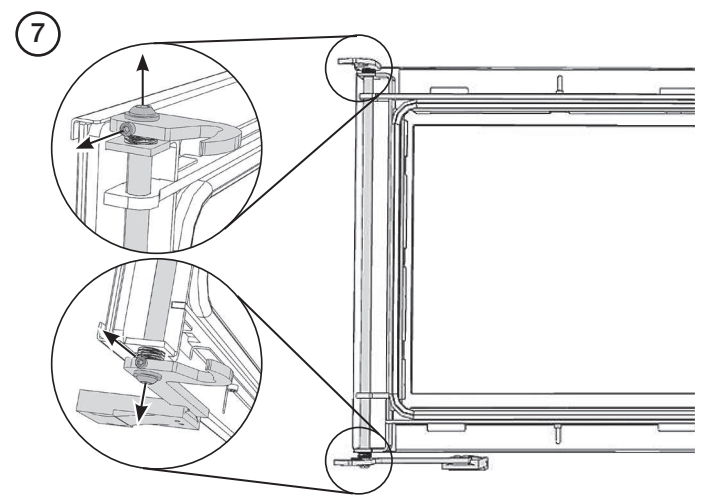
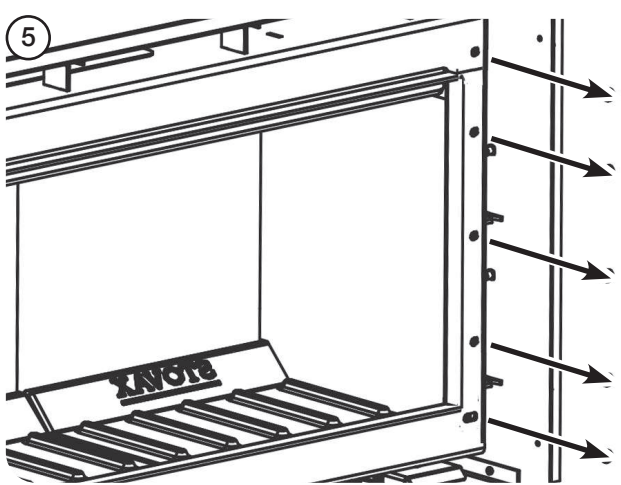
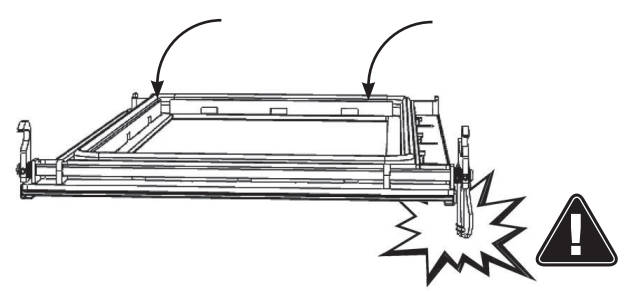
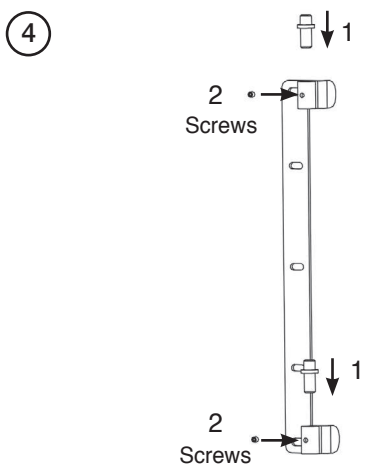

i Lie the door face down on a soft flat surface to protect the paint work and glass.

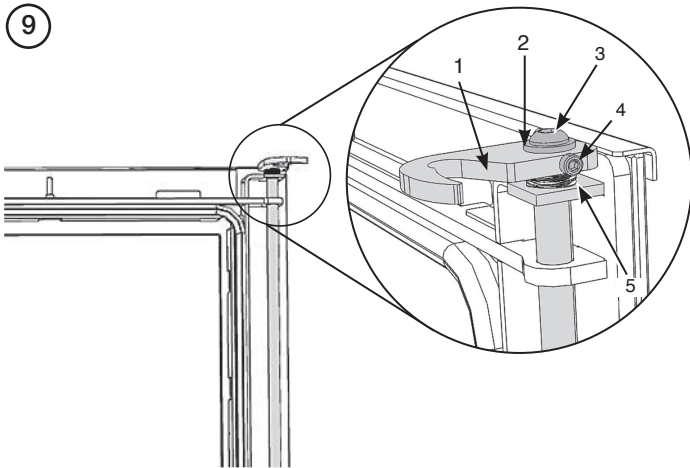

1. Top Latch
2. Washer
3. Large Screw
4. Small Screw
5. 2x Springs

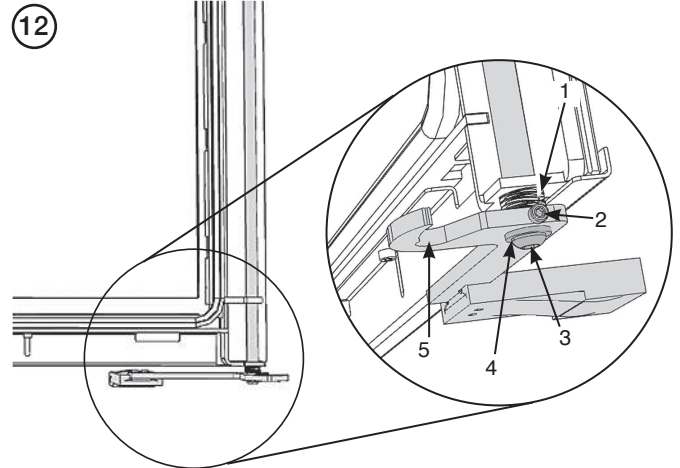

1. 2x Springs
2. Small Screw
3. Large Screw
4. Washer
5. Bottom Latch

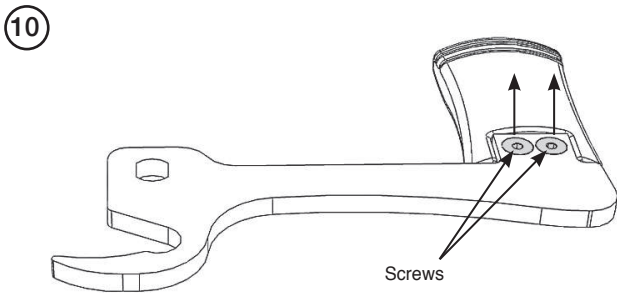

i Note: In order to change the door orientation the existing door latch will need to be replaced with a Reversible Door Handle Latch: Stovax Part No. 326-929. Retain original Latch to return the door to its original state.

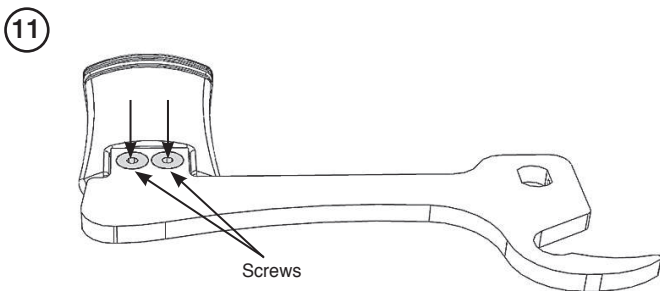

Door Catches

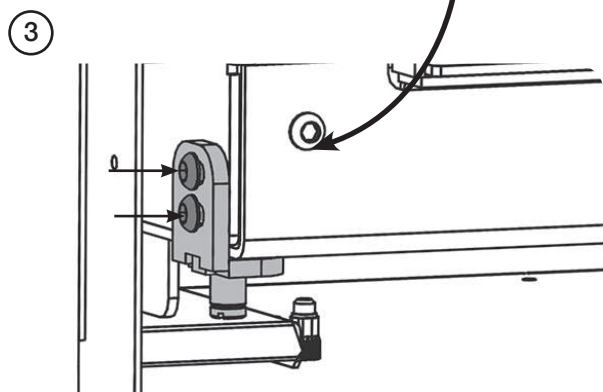
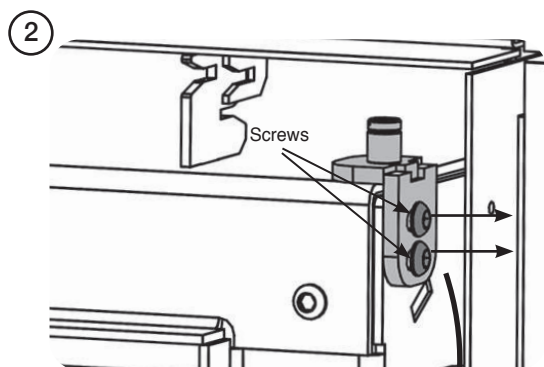
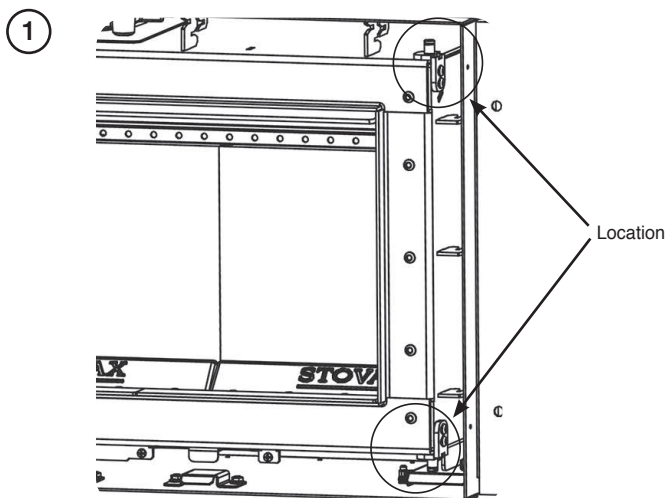

i Blank off the holes on the opposite side of the box with the screws previously removed.

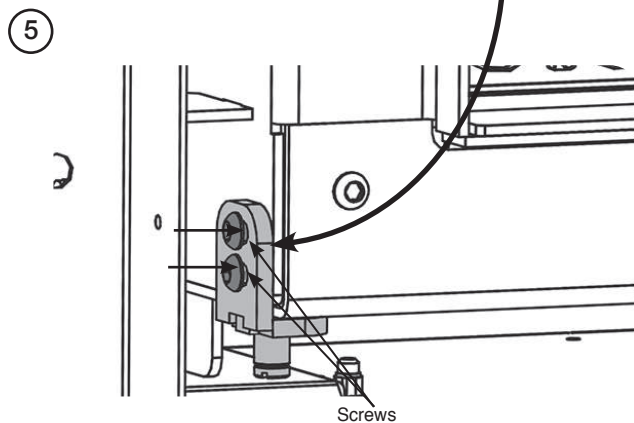
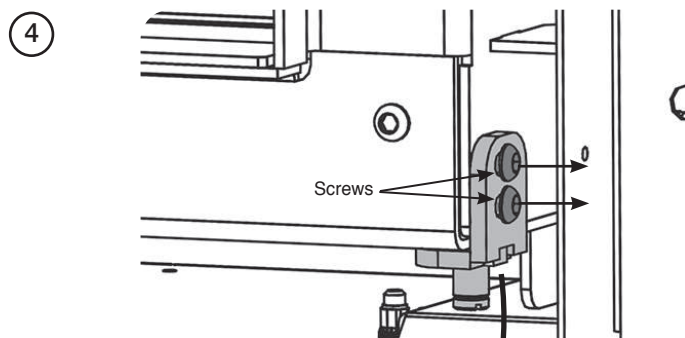

i Blank off the holes on the opposite side of the box with the screws previously removed.

Refit door.

i After reversing the door it may be necessary to adjust the door hinges and catches to ensure the safe, correct closing of the door. The door must be horizontal/level with the top of the inner box and the door catch engages correctly. See Maintenance & Servicing.

COMMISSIONING

To commission:

- Replace the internal components.
- Check the door alignment and catch operation and adjust if required.
- Check the soundness of door seals, castings and joints.
- Check the operation of the air controls.

Now carry out a final smoke draw test:

- Warm the flue with a blowlamp, or similar, for about 10 minutes.
- Place a smoke pellet on the centre of the grate, with the air controls open.
- Close the door. Smoke should now be drawn up the flue and be seen to exit from the flue terminal.
- Complete test with all doors and windows closed in the room where the appliance is fitted.
- If there are any extractor fans in adjacent rooms the test must be repeated with the fans running on maximum and with interconnecting doors open.
- Check the effect of ceiling fans during the test.

If excessive spillage occurs allow the appliance to cool and re-check the flue system and ventilation.

Finally:

- Explain to the user the correct operation of the appliance, use of the controls and the importance of only using suitable fuels in order to reduce smoke emissions - particularly if they live in a Smoke Control Area.
- Ensure that a CO alarm has been fitted and make the user aware of its operation and importance, referring them to the Warning section on page 5 of the User Instructions.
- Explain the cleaning and routine maintenance requirements.
- Explain the requirement to use a suitable fireguard when children, elderly or infirm persons are near the appliance.
- Record retailer/supplier and installer details in Appliance Commissioning Checklist.
- Record serial number in Appliance Commissioning Checklist. The serial number is found on the appliance data plate.

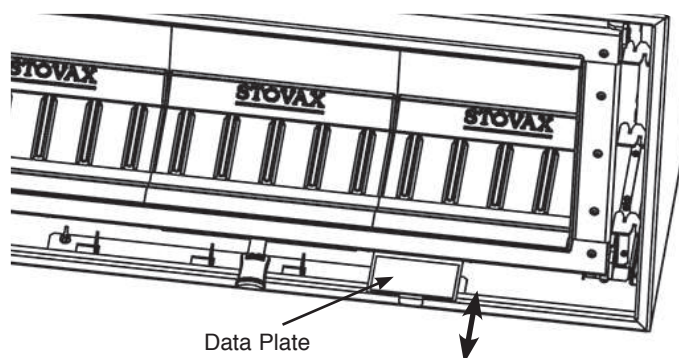

This number is required when ordering spare parts and making warranty claims.

- Give this instruction manual to the customer for future reference.

SERVICING

For a complete list of spare parts and accessories contact your Stovax Retailer or visit www.stovaxspares.co.uk

Before the start of the heating season strip, inspect and clean the appliance as detailed:

- Allow appliance to cool.
- Remove all internal parts: baffle, log guard, cast bases and firebricks.
Take care handling firebricks as they can become fragile after a period of use.
- Sweep the appliance at this point if necessary.
- Vacuum clean any remaining ash and debris from the inside of the appliance. Stovax offer a filter/collection attachment for vacuum cleaners to protect them from fire ash: Ash Clean (Stovax Part No. 2091).
- Check the parts for any damage. Replace any damaged parts using genuine Stovax replacements parts.
- Check and clean the firebricks with a soft brush.
Some surface damage will occur during use. The life of the bricks will depend on the type of fuels burnt and the level of use.
Replace damaged bricks as soon as possible.
- Re-fit cleaned internal parts.
- **Use Stovax Glass Cleaner (Stovax No.4103) which is better formulated for this application.**
Do not use abrasive cleaners to remove tar or soot deposits from the glass.
- Fit new door rope seal.
- Lightly oil the door catch mechanism and hinge pins. Avoid getting oil onto the door seals and glass.
- To refresh painted finishes a touch up spray is available.
Contact your Stovax retailer quoting the serial number found on the appliance data badge.

Use genuine Stovax replacement parts to keep the appliance in safe, efficient working order. This is a list of the maintenance products that may need be required:

Products to assist in the cleaning and maintenance of your Studio Air are available online at www.stovax.com or from your local Stovax dealer which, along with regular maintenance and use of correct fuels, will keep the appliance in the best possible condition.

For more information about the Stovax Group products please visit our web site at www.stovax.com

Burn at a low temperature for the first day of use after any maintenance. This allows the seals, fixing glues and paint to fully cure.

During this time the appliance may give off some unpleasant odours. Keep the room well ventilated to avoid a build-up of fumes.

Your Stovax dealer can carry out service and maintenance.



IMPORTANT: Stovax provide gauntlet style gloves for the users protection from heat and any sharp edges when using the appliance. For your safety ensure that gloves are always worn when opening, operating, refuelling or handling internal metalwork.

TASK	PRODUCT NAME	NO.
Preventing build-up of creosote in flue	Protector (15 sachets)	7002
	Protector (1kg tub)	7025
Sealing flue pipe joints	Fire Cement (500g tub)	2024
	Fire Cement (600g cartridge)	2021
Re-painting	Touch Up Paint (150ml aerosol)	2056
Protecting your hands	Heat resistant leather gloves	4008 4027 - Long
Thermic seal glue	(50ml bottle)	5037
Cleaning Glass	Stovax Glass Cleaner	4103
Ash Clean	Vacuum Cleaner Attachment	2091M

FITTING A NEW DOOR SEAL

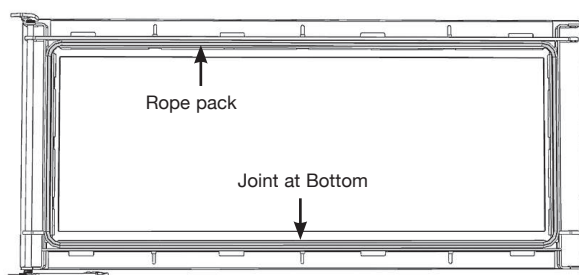
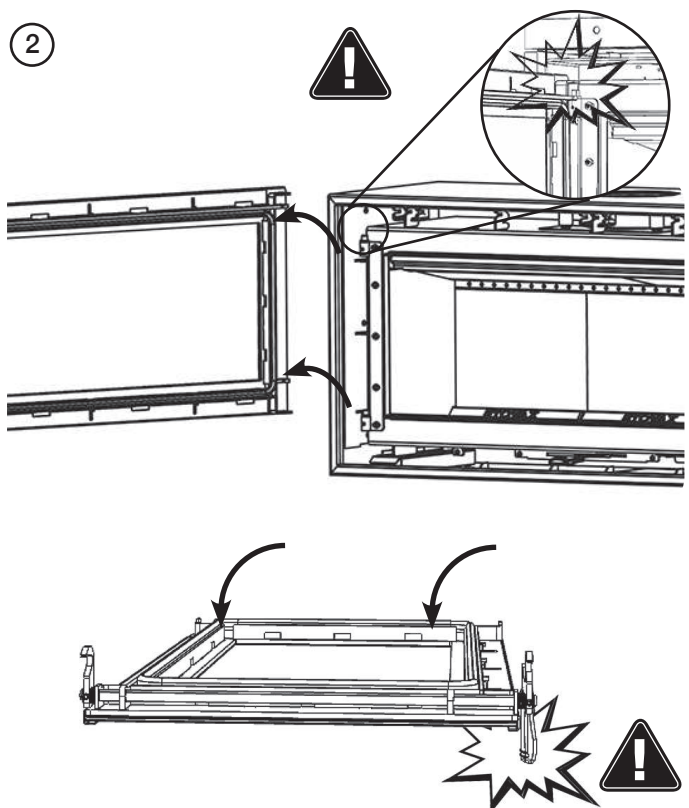
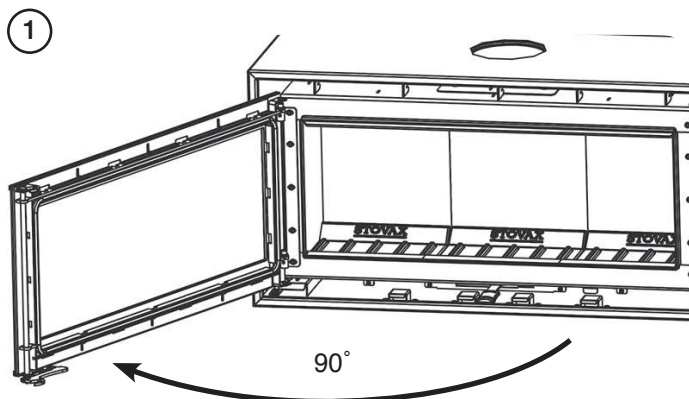

To maintain the safe use of your appliance you need to replace damaged or worn door sealing rope. To complete this operation remove the door before starting.

Remove the old rope and scrape old glue from the locating groove. Clean the locating groove with a clean dry cloth to remove all old dust and debris.

Squeeze a generous bead of fresh Stovax Thermic Seal glue into the rope locating groove.

Press the new Stovax rope into the locating groove, placing the joint in the middle of the bottom edge of the door using tape supplied for the ends.

Refit the door and close the door to apply pressure to the new rope.

Leave the appliance closed for at least 12 hours before lighting the appliance and using at a low output for approximately one day.

Using the appliance with a damaged door seal can cause dangerous fumes to enter the room, or the appliance to over fire, resulting in damage.

ADJUSTING DOOR HINGES

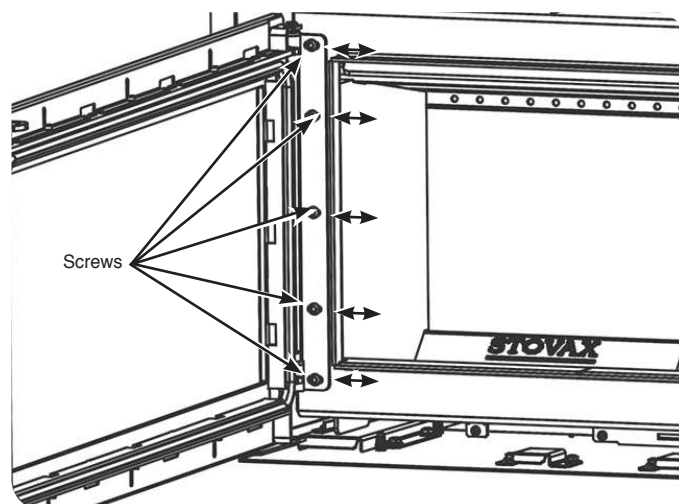

To maintain the safe use of your appliance, you may need to adjust the door hinges to ensure the safe, correct closing of the door. The door must be horizontal/level with the top of the inner box and the door catch engages correctly.

Adjustment is possible by adjusting the hinges on Inner Box.

Open the door to give access.

Hinges on Inner Box

Loosen the screws inside the appliance as shown. This will give horizontal adjustment which may need a trial and error approach to find the correct position. The door must be horizontally level.

ADJUSTING THE DOOR CATCH

To maintain the safe use of your appliance you may need to adjust the door catch to ensure the safe, correct closing of the door. If the door has been reversed or the door hinges have been adjusted the door catch may need adjustment.

The diagrams show adjustment for a door with hinges on the left. If the door has been reversed the method is the same.

The catches are located at the top and the bottom of the open side of the door.

The top and bottom catches will need to be adjusted separately and in the same manner.

The catch block can move in and out.

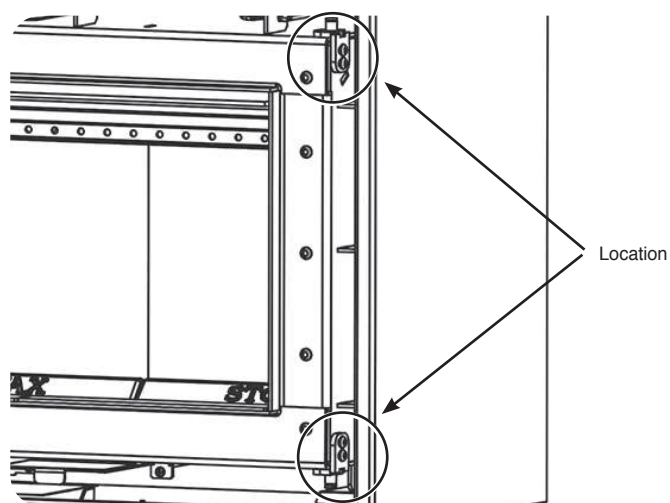

Top Catch Block

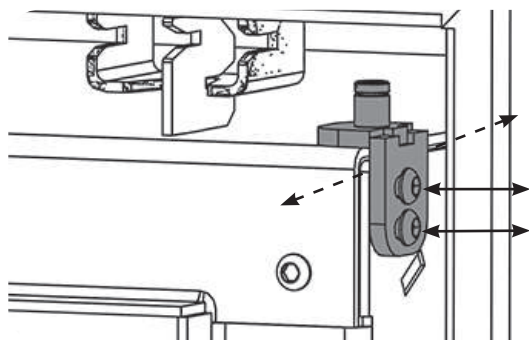

Bottom Catch Block

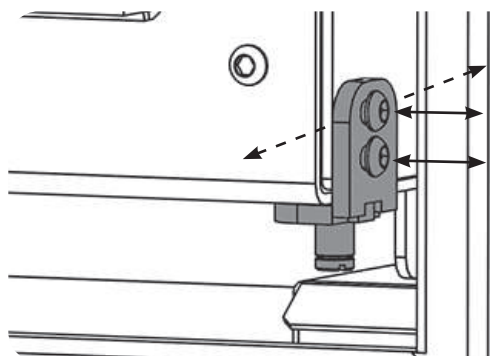

Loosening or tightening the M6 screw on the catch block will cause the catch to move in or out from the door and allow the hook to gain better purchase on the door rollers.

Do not remove screw completely.

DO A PAPER TEST

To do a paper test shut a piece of paper in the door at the edges to test how well the rope seal stops the air from entering the appliance. If the paper can be pulled out easily then the seal is not sufficient and the rope must be replaced.

Repeat this around all the edges of the appliance.

PRODUCT FICHE - INFORMATION REQUIREMENT FOR SOLID FUEL LOCAL SPACE HEATER

Model	Studio Air 1	Studio Air 2
Direct Efficiency Class	A	A
Direct Heat Output (kW)	5.0	8.2
Indirect Output (kW)	-	-
Energy Efficiency Index (EEI)	106	105
Useful Energy Efficiency at Nominal Heat Output	79.6%	78.5%
Safety Precautions	Appliance must be installed, Used and Maintained in accordance with the manufacturers instructions supplied	

PRODUCT MATERIAL INFORMATION

The following substances, preparations or components should be disposed of or recovered separately from other WEEE in compliance with Article 4 of EU Council Directive 75/442/EEC.

Metal	Steel	Can be taken to a local recycling centre for reuse to reduce waste going to landfill.
	Cast iron	
Glass		Can be taken to a local recycling centre for reuse to reduce waste going to landfill.
Vermiculite linings		Non hazardous material. Vermiculite can be crushed up and used for plant bedding and ash used for composting or disposed of at a local recycling centre for reuse to reduce waste going to landfill.
Rope seals		Rope seals are made from Refractory Ceramic Fibre (RCF), a material which is commonly used for this application. Protective clothing is not required when handling these articles, but it is recommended to follow normal hygiene rules of not smoking, eating or drinking in the work area and always wash hands before eating or drinking. When servicing the appliance it is recommended that the replaced items are not broken up, but are sealed within heavy duty polythene bags and labelled as RCF waste. RCF waste is classed as stable, non-reactive hazardous waste and may be disposed of at a licensed landfill site.
Electrical components	(Fan kits etc if applicable)	Dispose of at a local recycling centre in accordance with the WEEE directive.

INFORMATIONS GÉNÉRALES

Installation D'appareil

Chaque installation est unique au bâtiment, il n'est donc pas possible de donner des détails appropriés à chaque site. L'installation doit être conforme à la réglementation sur la construction des bâtiments et doit utiliser les bonnes pratiques de construction.

Prendre soin lors de l'installation du poêle. La manutention inappropriée ou une mauvaise utilisation des outils peut endommager la finition et/ou la surface adjacente.

Emplacement de l'appareil

Un grand nombre de cheminées comportent un linteau. Ne jamais enlever le linteau sans supporter le reste de la structure du bâtiment. Ne pas faire supporter la structure ou le conduit de fumée par l'appareil.

Si vous faites l'installation avec un kit d'air extérieur et , veuillez svp consulter les manuel PM1690FR avant l'installation.

Professionnel immatriculé :

Avant de procéder à l'installation ou d'utiliser cet appareil, veuillez lire l'ensemble de ces instructions avec attention de manière à bien comprendre leurs exigences.

Cet appareil doit être installé par un installateur agréé, ou approuvé par le bureau de contrôle de construction le plus proche.

Support structurel :

pour une installation sur un sol en bois, vérifiez que les solives soient suffisamment robustes pour supporter le poids de l'insert, de la cheminée et des éléments de construction.

Foyer :

un foyer construit avec une profondeur de 125 mm et une plaque d'âtre décorative de 12 mm doit être installé pour protéger le sol combustible du risque de chute de braise pour un montage direct sur le sol. L'âtre décoratif doit être étendu de 300 mm devant le foyer. Il peut être en pierre naturelle, béton, métal ou verre.

Inspection finale de l'installation :

Une fois installé, l'appareil doit être mis en service conformément aux normes et pratiques pour être en bon état de marche et effectuer une passation correcte au client.

Conduit et cheminée

Le système du conduit ou de la cheminée doit pouvoir résister à des températures de conduit allant jusqu'à 400°C.

Le diamètre extérieur du manchon de raccordement est de 155 mm.

En mode de fonctionnement normal, le tirage de la cheminée doit être de 20 à 25 Pa près du manchon de raccordement. Le tirage dépend surtout de la longueur et de la surface de la cheminée, mais également de son étanchéité.

La longueur minimale conseillée de cheminée est de 3,5 m et la surface de section appropriée de 150-200 cm² (140-160 mm de diamètre).

Les coudes à angle aigu et les longueurs horizontales du tuyau réduisent le tirage de la cheminée.

Le ramonage de toute la longueur du conduit doit être possible et les portes de ramonage aisément accessibles.

Contrôler soigneusement l'étanchéité de la cheminée et l'absence de fuite de fumée au niveau des raccords.

Alimentation en air de combustion

Une fois l'appareil installé, il est indispensable de veiller à une alimentation adéquate en air de la pièce. L'air peut être fourni indirectement par un évent sur le mur extérieur ou via une conduite venant de l'extérieur et raccordée au manchon sous l'insert. Le volume requis d'air de combustion est d'environ 20 m³/h.

Le diamètre extérieur du manchon de raccordement de l'air de combustion est de 80 mm.

Si le tuyau fait plus d'un mètre, son diamètre doit être augmenté à 100 mm et un évent mural plus grand est nécessaire.

Dans les espaces chauffés, le conduit doit être isolé pour éviter toute condensation grâce à une laine de roche de 30 mm couverte d'un écran à la vapeur d'eau. Le trou dans le mur (ou le sol) au niveau du point de sortie doit être convenablement scellé avec un composé pour joint de conduit.

Un tuyau flexible, reliant directement l'appareil à l'extérieur, est disponible et doit être fixé au moment de l'installation.

Détecteurs-avertisseurs de CO

Tous les appareils ouverts peuvent être affectés par des conditions atmosphériques temporaires capables de repousser la fumée dans la maison. Nous recommandons, lors de l'installation dans une habitation d'un nouvel appareil ou d'un appareil de chauffage de remplacement à bois ou multi-combustible qu'un détecteur-avertisseur de CO soit installé dans la même pièce que l'appareil.

La présence d'une alarme ne doit pas être considérée comme un substitut pour une bonne installation et un entretien et une maintenance régulière de l'appareil et de la cheminée.

DIMENSIONS

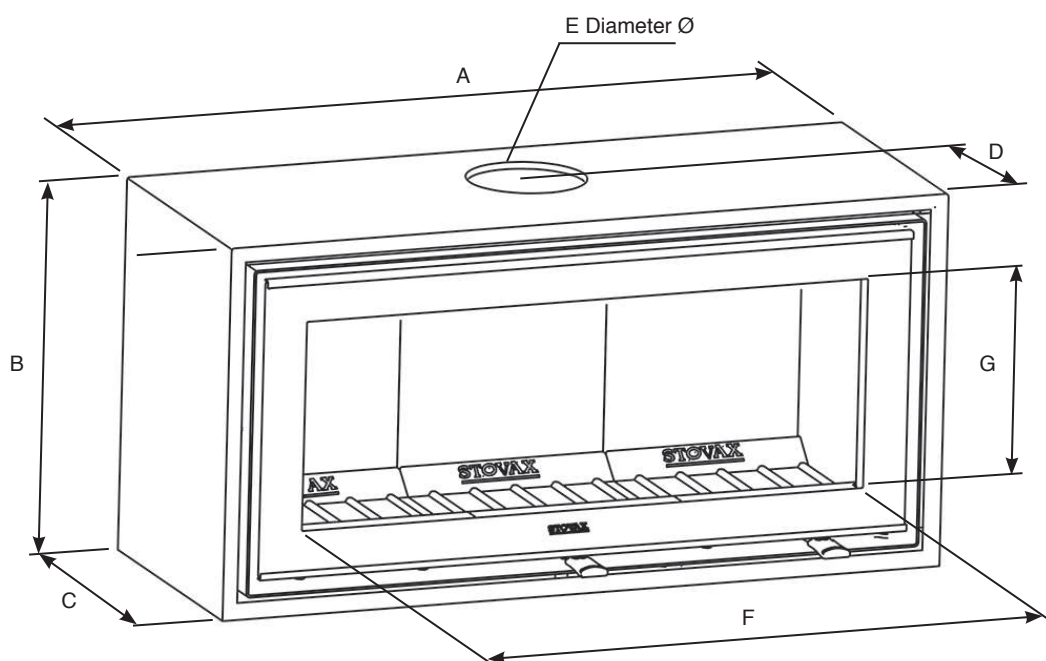

	A	B	C	D	E	F	G
Studio Air 1	809	481	382	234	152	590	259
Studio Air 2	1009	506	382	234	152	790	284

Toutes les dimensions sont en mm

D'AIR EXTÉRIEUR

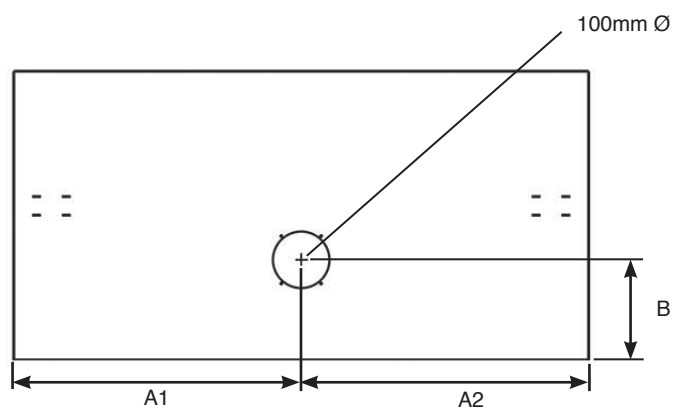

	A1	A2	B
Studio Air 1	404.5	404.5	174.5
Studio Air 2	504.5	504.5	174.5

DISTANCE DES MATÉRIaux COMBUSTIBLE

INSTALLATION FERMÉE

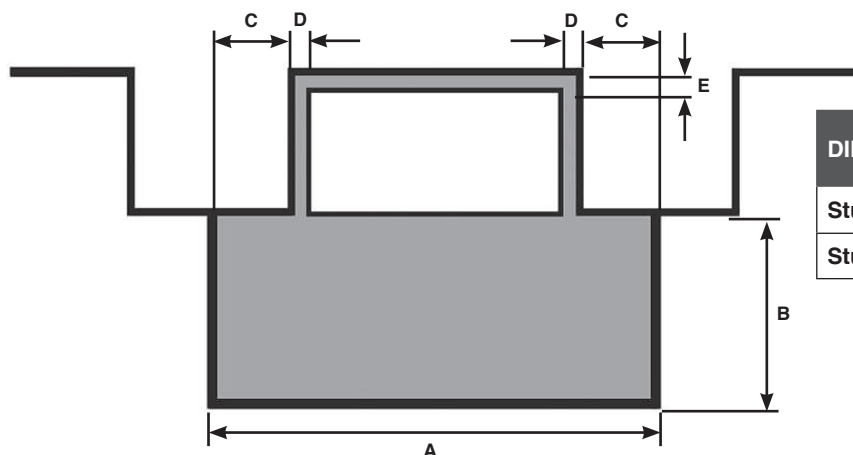

DIMENSIONS (MM)	A	B	C	D	E
Studio Air 1	1309	500	250	50	125
Studio Air 2	1609	700	300	50	125

INSTALLATION OUVERTE

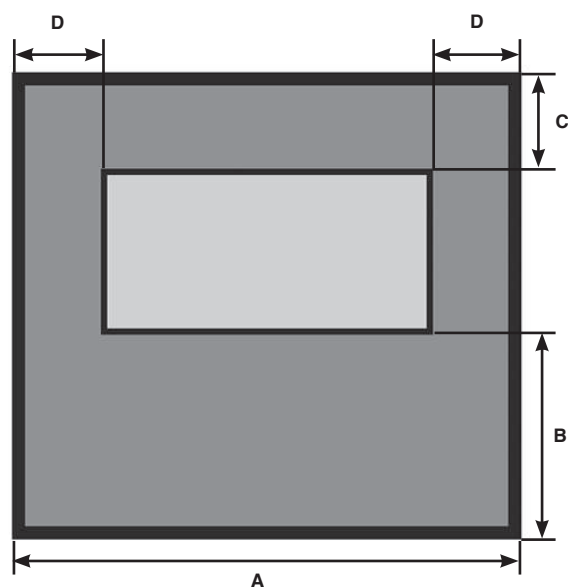

DIMENSIONS (MM)	A	B	C	D
Studio Air 1	1309	500	125	150
Studio Air 2	1609	700	125	180

ÉPAISSEUR DE L'ÂTRE

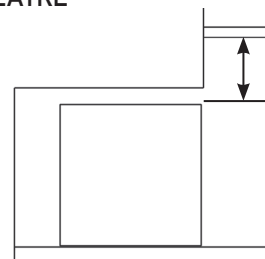

DIMENSIONS (MM)	HAUTEUR
Studio Air 1	500
Studio Air 2	800

HAUTEUR SOUS LE MANTEAU

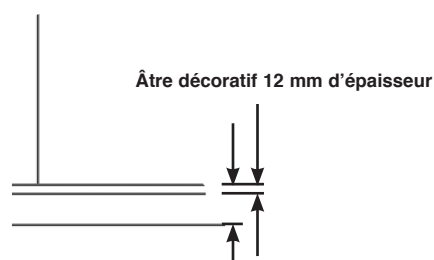

Épaisseur de l'âtre 125 mm
(Parties construite et décorative combinées)

Si cet appareil est installé sur un banc de Stovax, le banc peut se tenir sur un foyer non combustible de 12 mm d'épaisseur et il est recommandé que la profondeur de foyer de 225 mm soit augmentée pour contenir en toute sécurité les grumes de chute ou les braises.



*Stovax recommande une profondeur d'âtre décoratif égale ou supérieure à la hauteur de l'appareil à partir du sol OU à la longueur de la porte en position ouverte.
UTILISER LA TAILLE MA PLUS GRANDE.

DÉGAGEMENT PAR RAPPORT AUX MATÉRIAUX NON COMBUSTIBLES

DÉGAGEMENTS POUR INSTALLATION EN PARALLÈLE

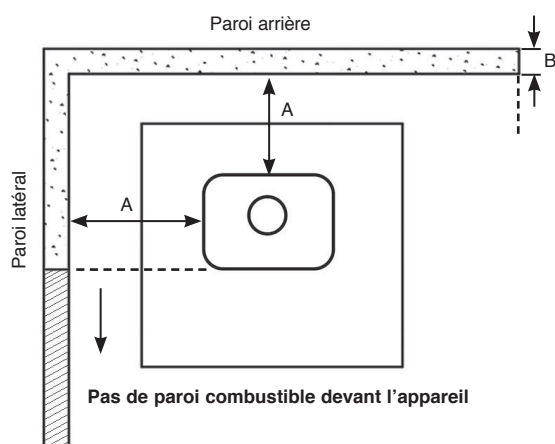

HAUTEUR SOUS LE MANTEAU

Cet appareil doit reposer sur une sole foyer incombustible d'au moins 125 mm d'épaisseur.

DISTANCE PAR RAPPORT AUX MATÉRIAUX NON COMBUSTIBLES

Distance entre l'appareil et le mur (A)	Épaisseur minimale du mur (B)	Hauteur minimale du mur (C)
0mm - 50mm	200mm	Hauteur de l'appareil + 300mm OU 1200mm à partir de la sole foyer (choisir la dimension la plus grande)
51mm - 300mm	75mm	
300mm+	Aucune exigence	Aucune exigence

Hauteur au-dessus de l'appareil

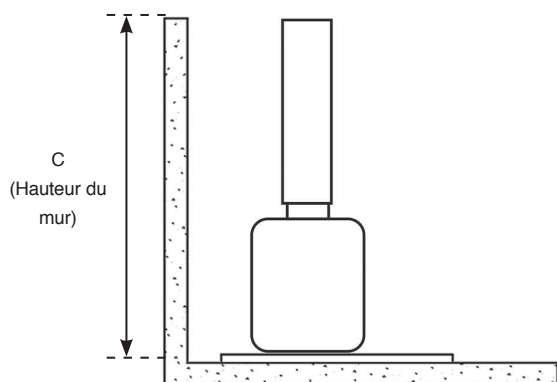

DÉGAGEMENTS POUR INSTALLATION EN ANGLE

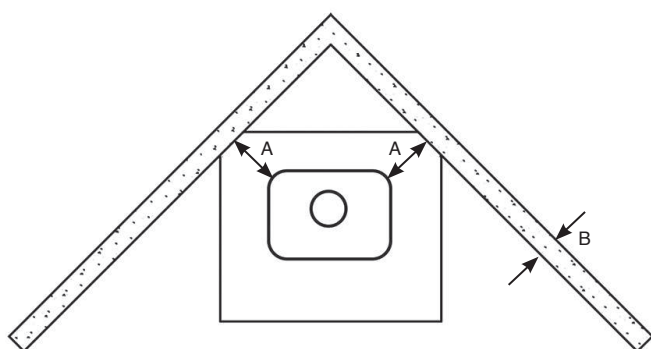

IDENTIFICATEUR DE PIÈCES

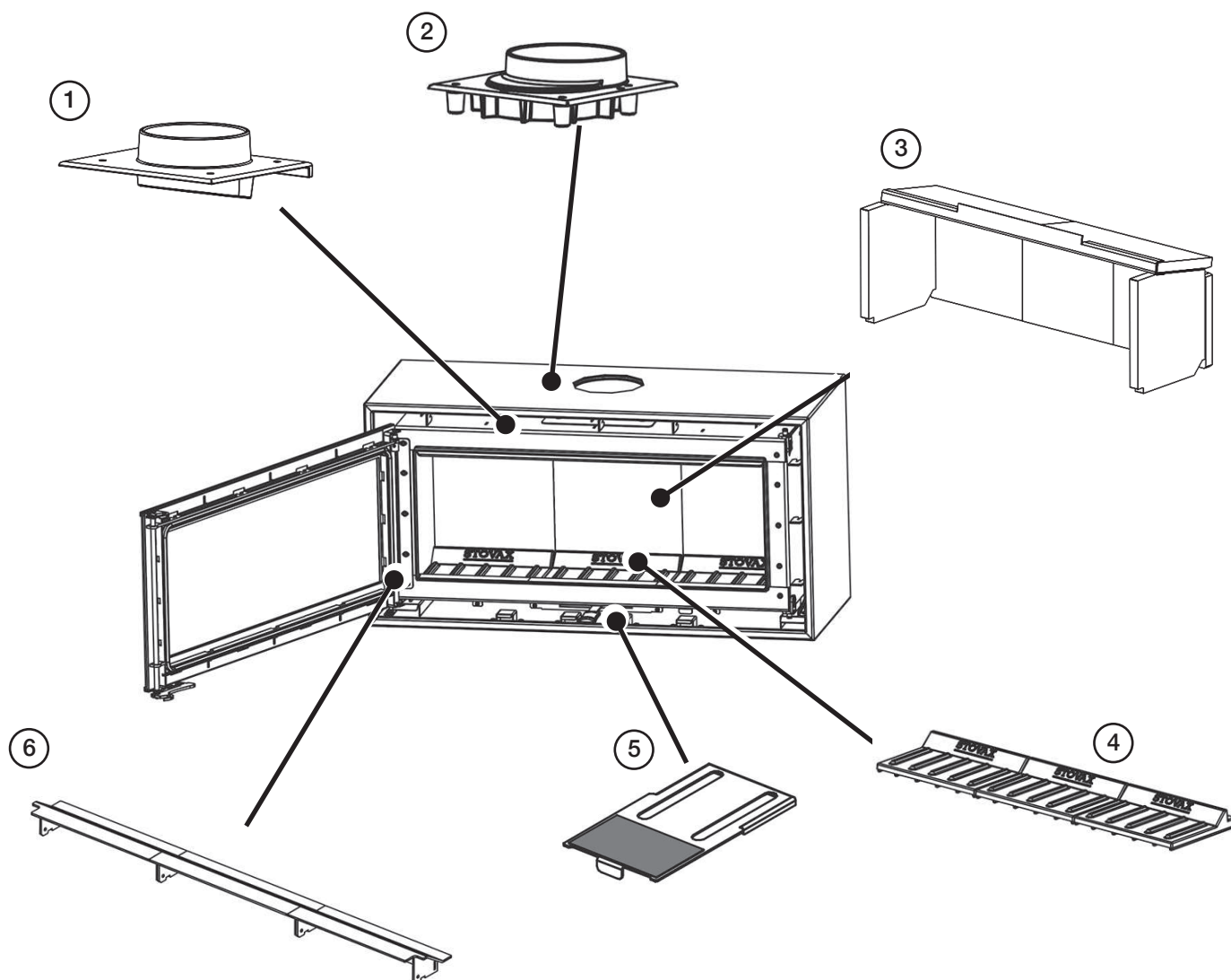

1. Buse de raccordement du conduit
2. Buse d'étanchéité
3. Briques intérieures et déflecteurs
4. Briques de sole foyer en fonte
5. Plaque signalétique
6. Garde-bûches

INFORMATIONS ESSENTIELLES

GÉNÉRALITÉS	Modèle:			Studio Air 1	Studio Air 2
	Puissance nominale	Bois	kW	6.2	8.2
	Rendement	Bois	%	81.4	78.5
	CO @ 13% O ₂	Bois	%	0.10	0.08
	Poids		Kg	123	165
Combustibles recommandés		Bois	Bois sec (taux d'humidité inférieur à 20%)		

Testés aux normes EN 13240 pour utilisation intermittente

CONDUIT DE FUMÉE	Taille interne de la buse de raccordement	Avec conduit interne ou dispositif fabriqué en usine (diamètre) installé en conformité avec les instructions du fabricant	mm	153	153
	Conduit de fumée/cheminée (hauteur minimum)	Tous les produits	m	4.5	4.5
	Tirage dans le conduit	Min	Pa	10	10
		Nominal		12	12
		Max		20	20
	Débit de masse de gaz dans le conduit	Bois	g/s	4.9	6.5
	Température des gaz dans le conduit au niveau de la buse de départ	Bois	°C	261	304
Diamètre du conduit		mm	153	153	

Spéc. européenne min. pour les conduits de fumée - T400 N2 D 3 G50

VENTILATION	Habitations de construction traditionnelle			
	• Ventilation Min de 50cm ²			
	Ventilation	mm ²	5000	5000
cm ²		50	50	

INSTRUCTIONS AVANT L'INSTALLATION

Pour faciliter l'installation de l'appareil, il est préférable d'enlever les composants internes avant de l'installer dans l'ouverture/ossature.

PORTE

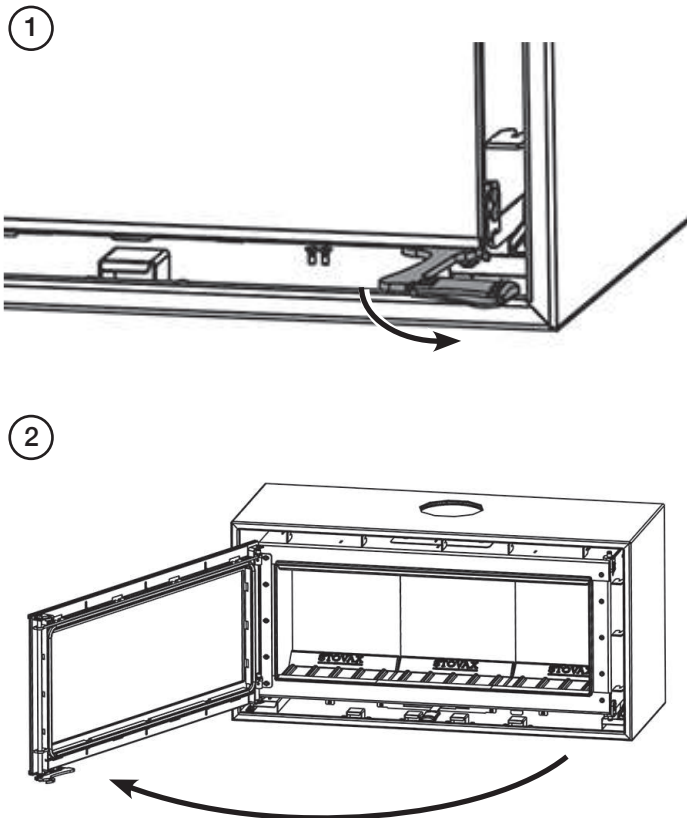

GARDE-BÛCHES

Ne pas utiliser l'appareil sans garde-bûches.

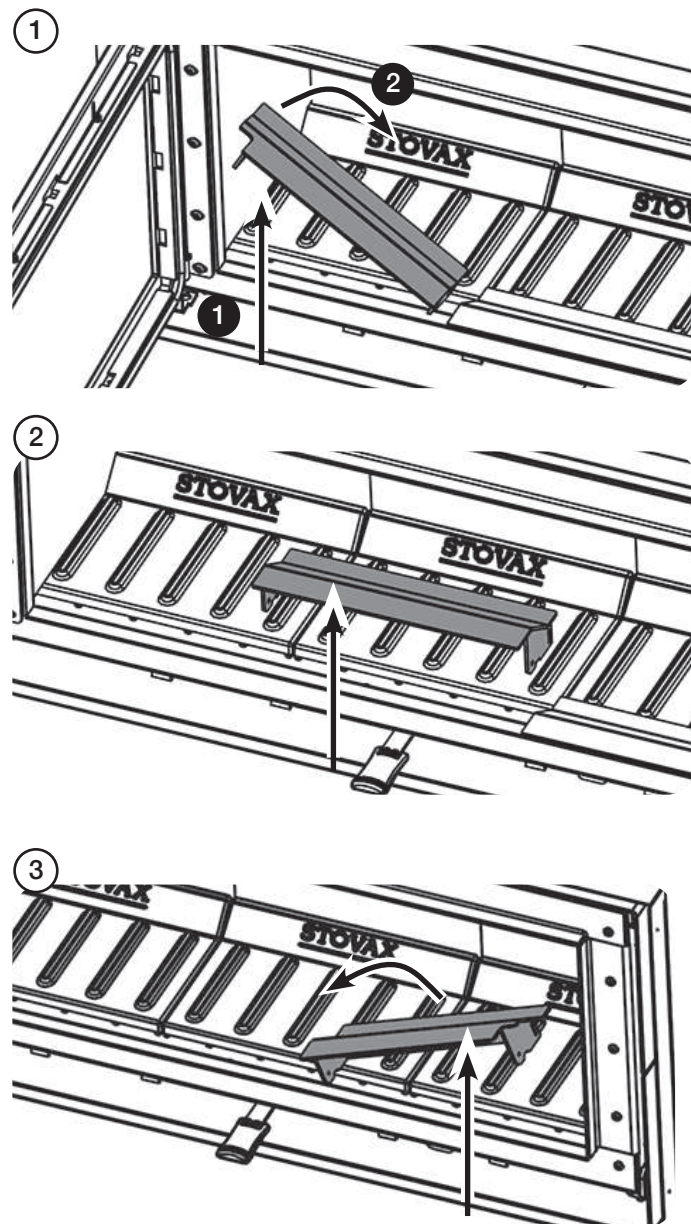

i Les garde-bûches gauche et droit ne sont pas interchangeables. Les découpes doivent être placées sur le côté extérieur du corps de chauffe face vers l'avant.



BRIQUES RÉFRACTAIRES ET DÉFLECTEUR

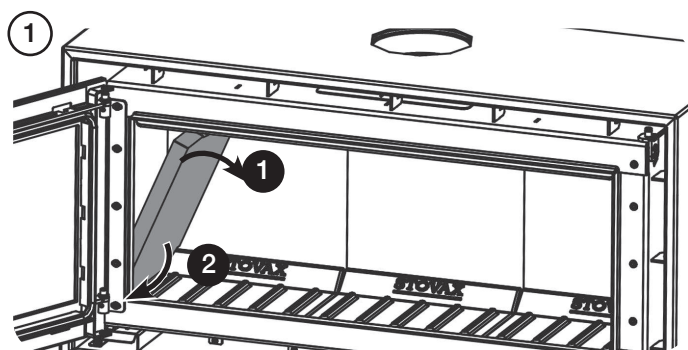

Support de la barre du déflecteur

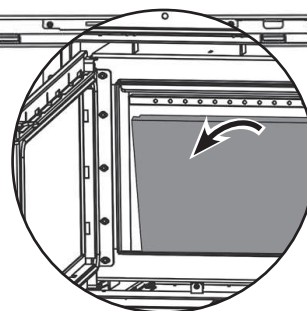
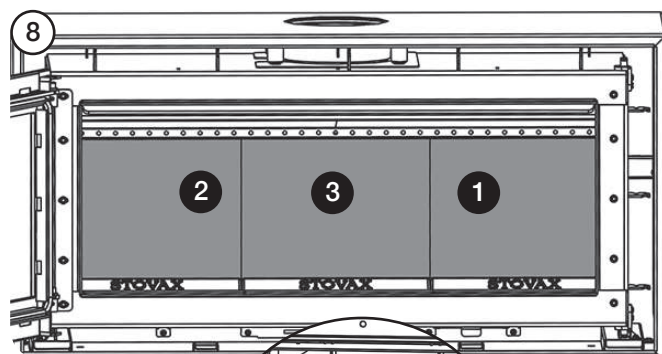
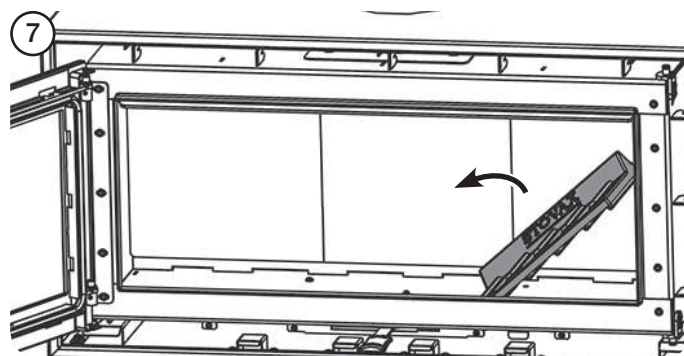
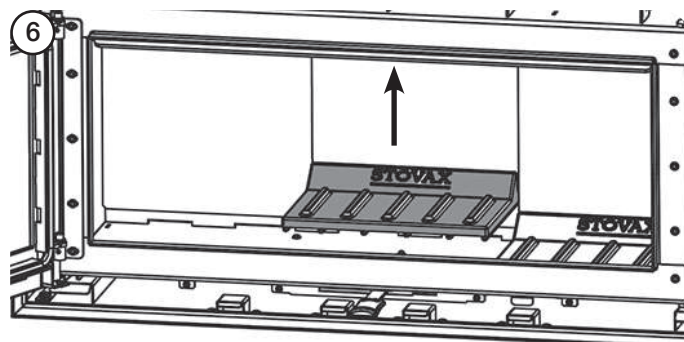
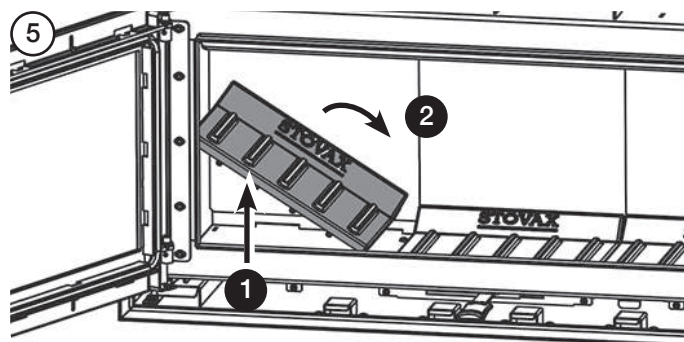
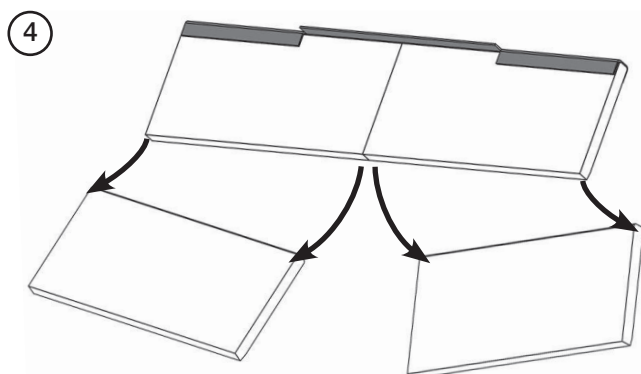
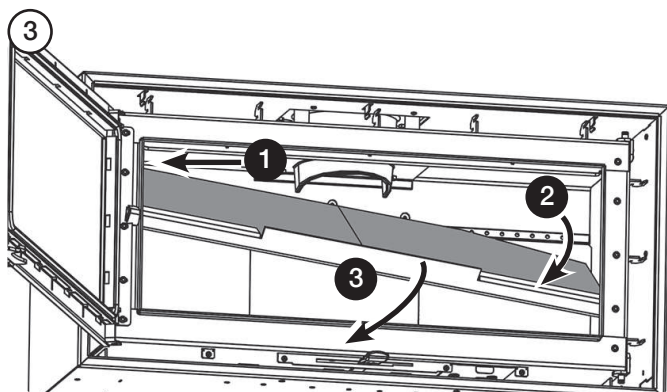
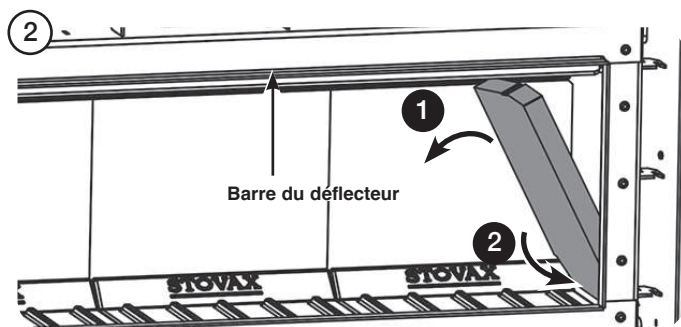

BUSE D'ETANCHÉITÉ

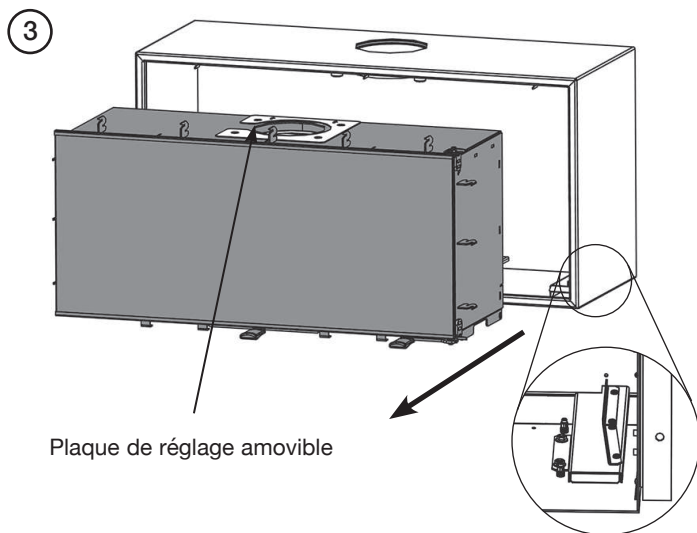
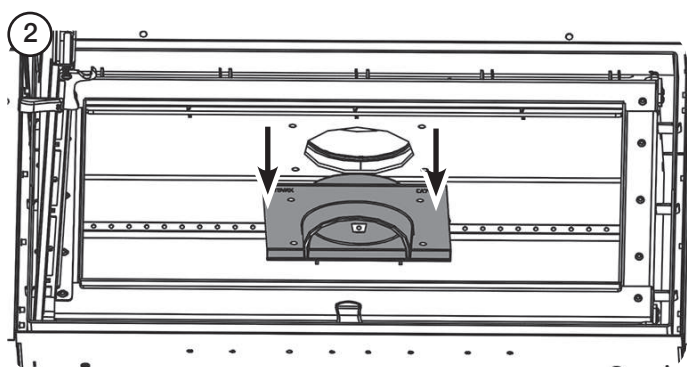
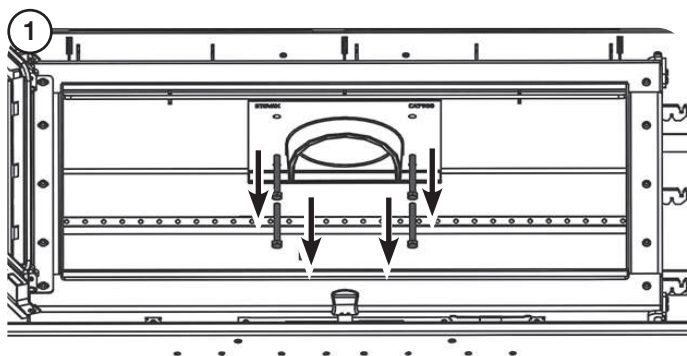

RETRAIT DE LA BUSE DE RACCORDEMENT

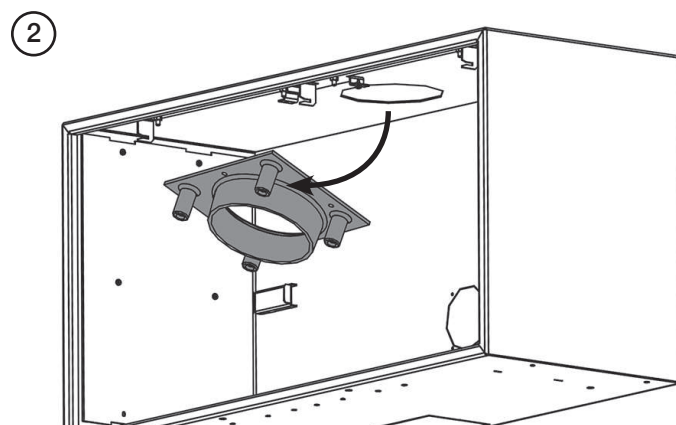
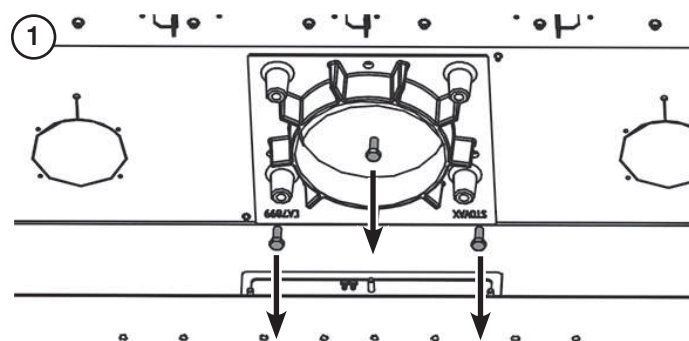
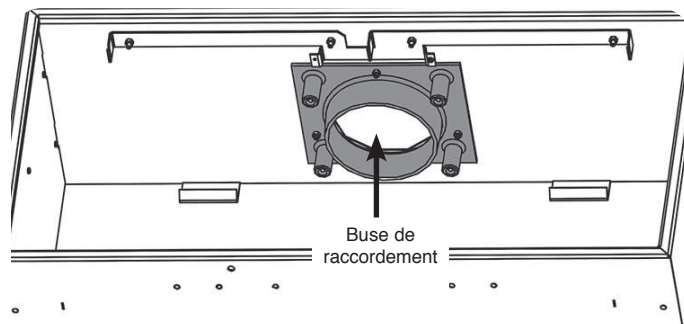

Les boulons sont situés dans les 4 cavités sur la buse de raccordement.
La buse de raccordement reste en place pour l'installation du conduit.

INSTALLATION

INSTALLATION D'APPAREIL

Chaque installation est unique au bâtiment, il n'est donc pas possible de donner des détails appropriés à chaque site. L'installation doit être conforme à la réglementation sur la construction des bâtiments et doit utiliser les bonnes pratiques de construction.

Un grand nombre de cheminées comportent un linteau. Ne jamais enlever le linteau sans supporter le reste de la structure du bâtiment. **Ne pas faire supporter la structure ou le conduit de fumée par l'appareil.**



NOTE: Si vous faites l'installation avec un kit d'air extérieur et, veuillez svp consulter le manuel PM1690FR avant l'installation.

EXTRAS EN OPTION

Les options suivantes peuvent améliorer les performances de l'appareil et doivent être fixées au moment de l'installation.

PLATE DÉCORATIVE DE CONDUIT DE FUMÉE

Cet appareil peut être installé sur un banc. Plusieurs tailles disponibles. L'installation de cet élément doit être effectuée au moment de l'installation. Veuillez vous reporter aux instructions.

KIT ÉTANCHE D'AIR EXTÉRIEUR.

Cet appareil peut être installé avec un kit étanche d'air extérieur pour amener l'air dans le corps de chauffe directement depuis l'extérieur.

Pour l'installation et l'utilisation, se référer aux instructions du kit d'air extérieur.

BANC

Cet appareil peut être installé sur un banc. Plusieurs tailles disponibles. L'installation de cet élément doit être effectuée au moment de l'installation. Veuillez vous reporter aux instructions.

INSTALLATION

Prendre soin lors de l'installation du poêle. La maintenance inappropriée ou une mauvaise utilisation des outils peut endommager la finition et/ou la surface adjacente.

FIXATION DE L'APPAREIL À L'ÂTRE

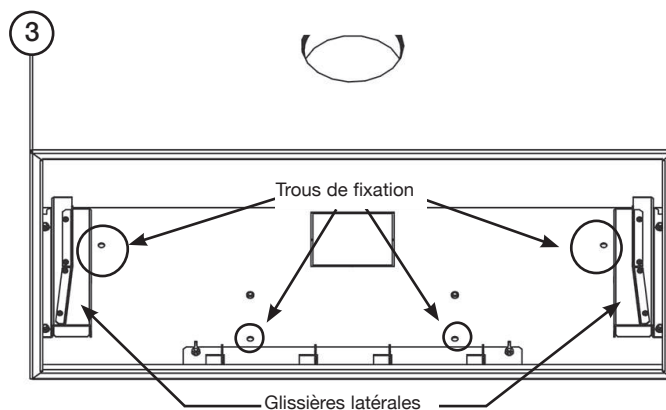
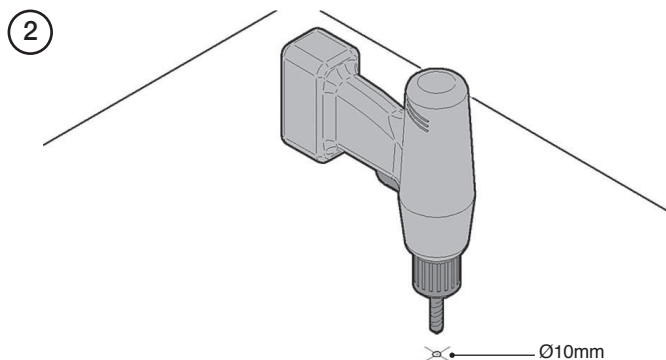
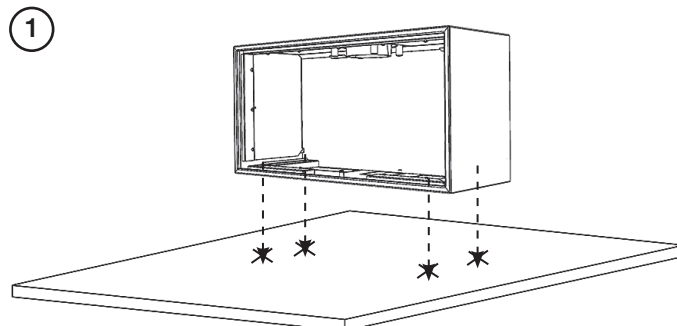

Le boîtier extérieur ne peut être remonté qu'avec la commande d'air en position centrale.

REMISE EN PLACE DES BUSES DU CONDUIT

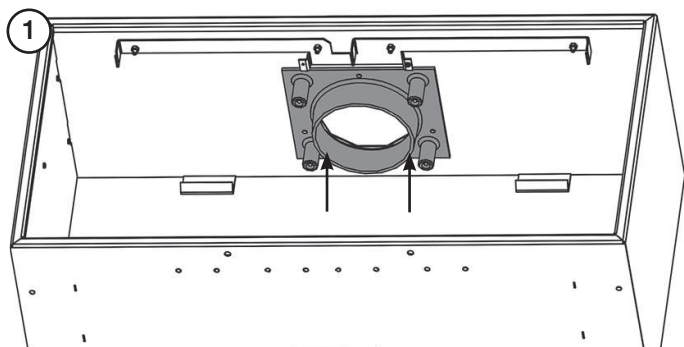

Insérer sans serrer les boulons courts (1) et insérer ensuite les boulons plus longs (2).

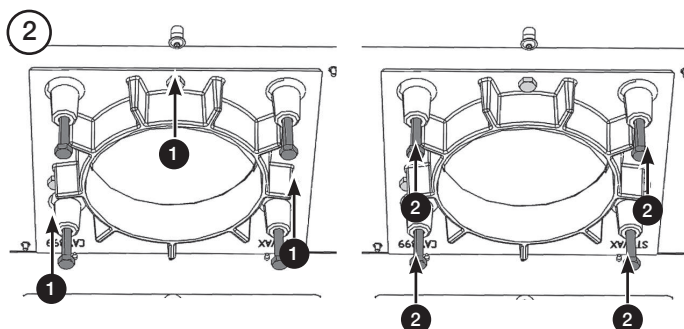

Serrer les boulons courts.

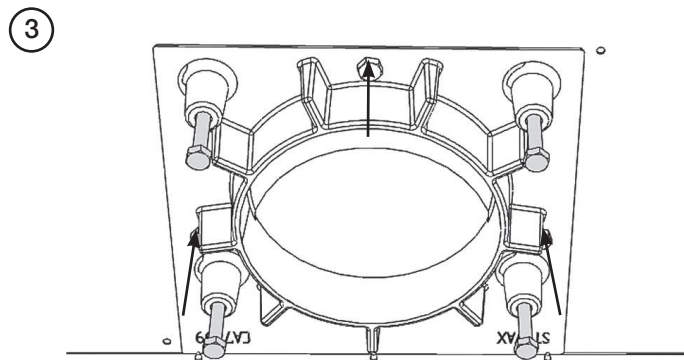

Retirer les boulons plus longs.

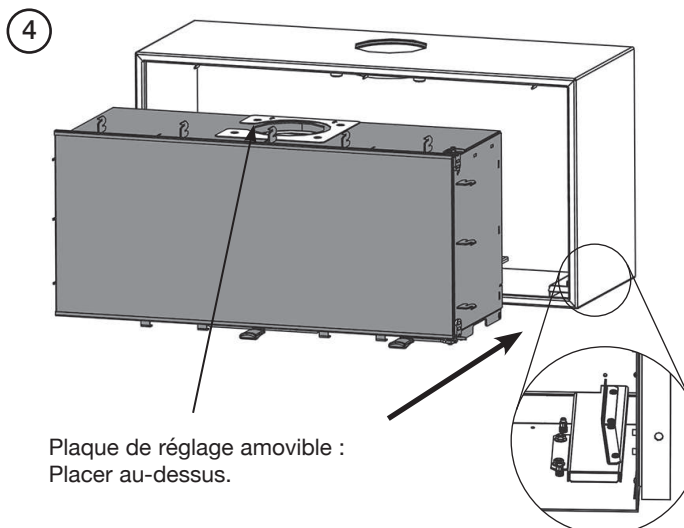

Plaque de réglage amovible :
Placer au-dessus.

5

Buse d'Étanchéité

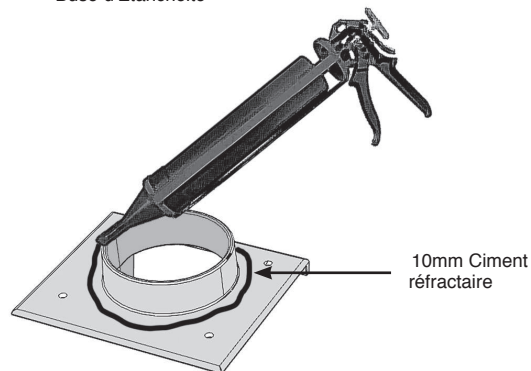

10mm Ciment
réfractaire

6

Boîtier interne ôté pour plus de clarté

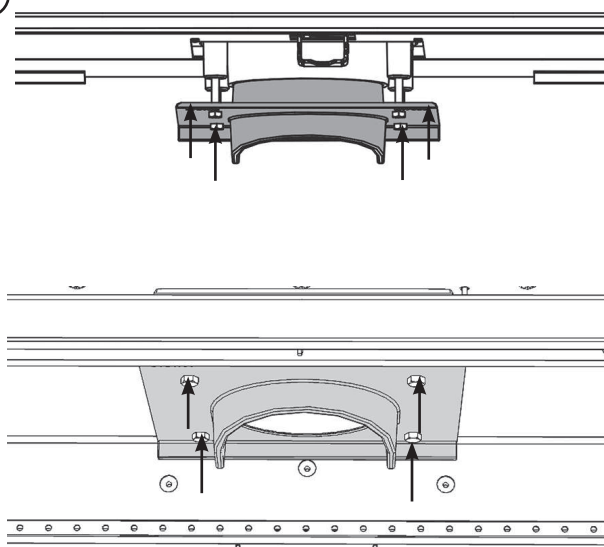

REMISE EN PLACE DES BRIQUES RÉFRACTAIRES

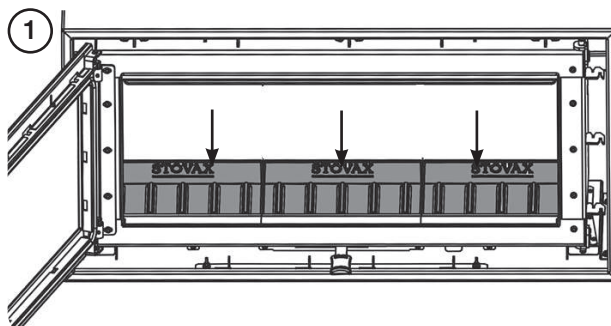

2

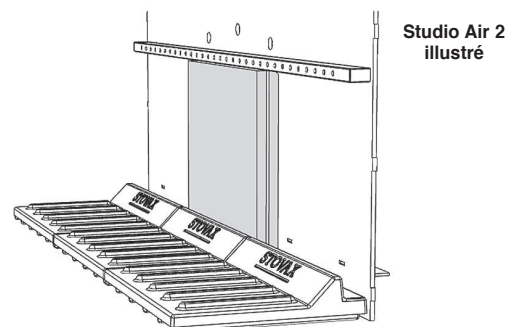

Studio Air 2
illustré

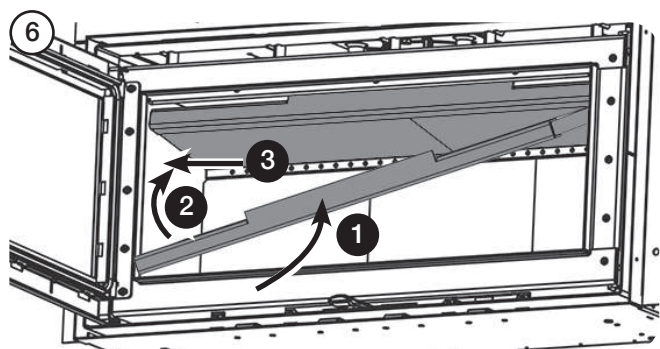
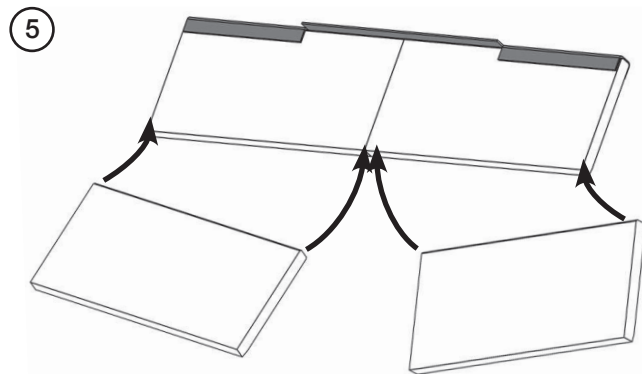
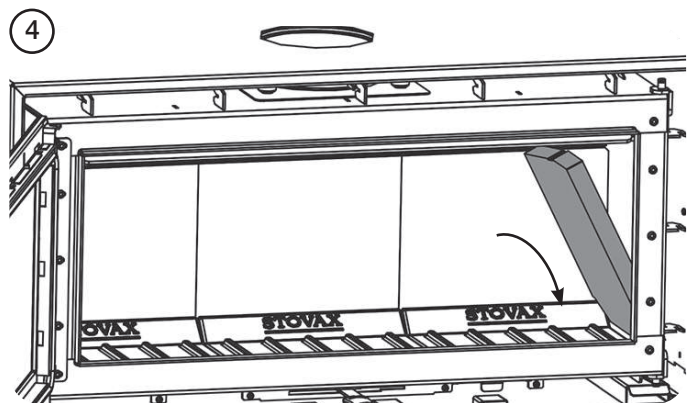
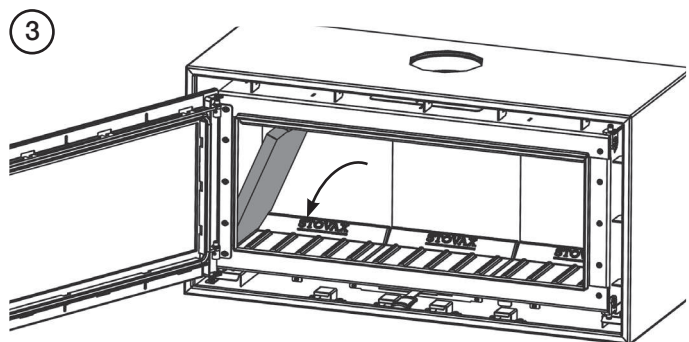
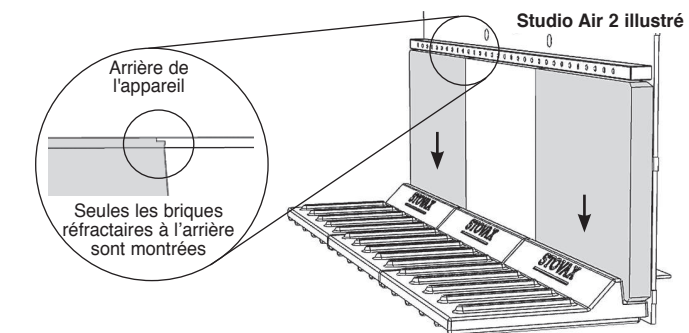

FIXATION DE LA FINITION DÉCORATIVE

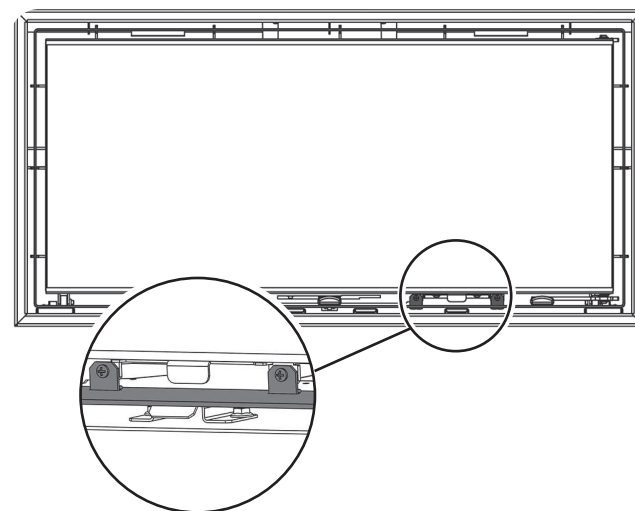
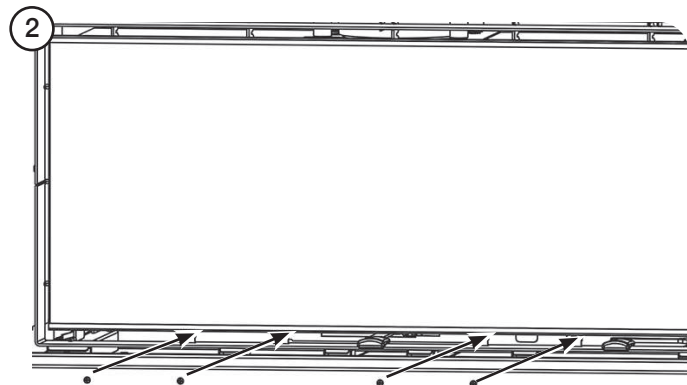
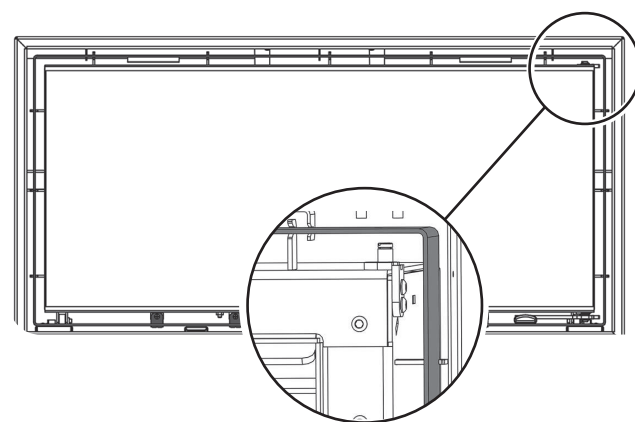
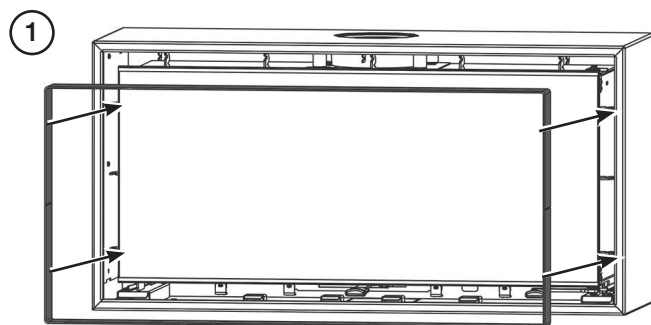

INVERSION DE LA PORTE

i

Pour changer l'orientation de la porte, un loquet réversible de poignée de porte doit être acheté préalablement auprès de Stovax. Référence produit :326-929.
Conserver le loquet d'origine pour ramener la porte à son ouverture initiale.

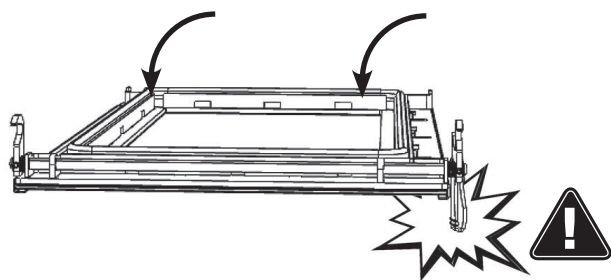
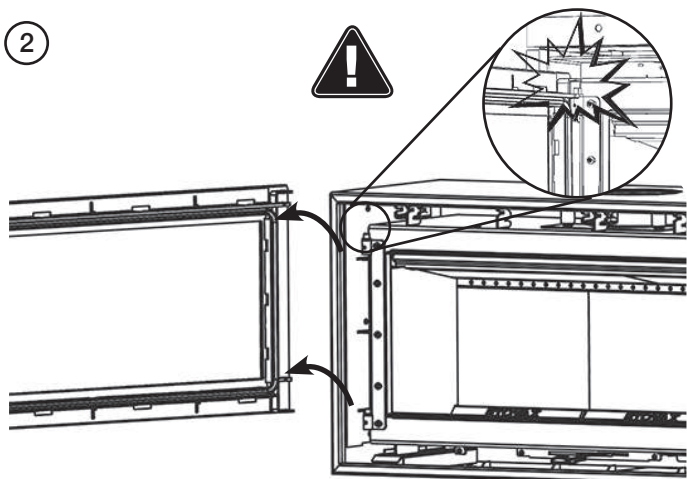
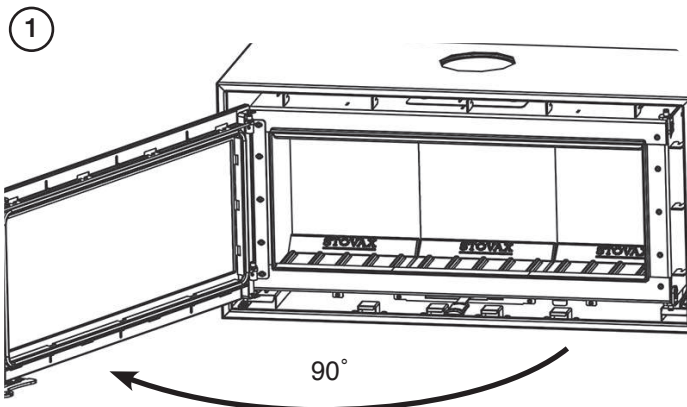

i

Après inversion de la porte, il peut s'avérer nécessaire d'ajuster les charnières et les crochets pour une bonne fermeture de la porte en toute sécurité. La porte doit être à niveau du haut du boîtier interne et les crochets bien enclenchés. Voir Maintenance et Révision.

Assemblage des charnières

①

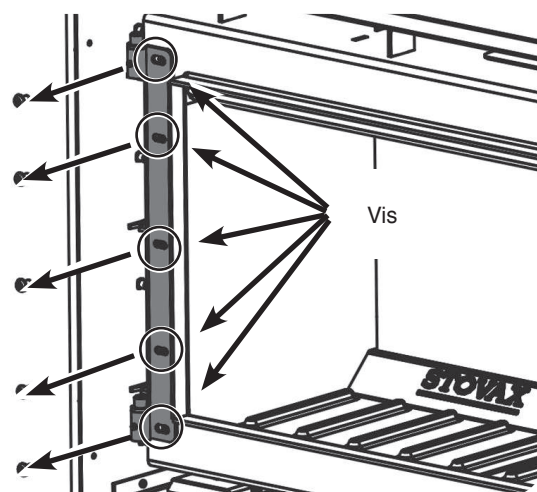

②

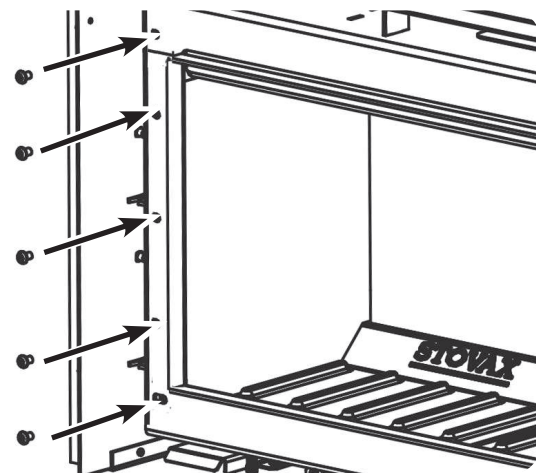

③

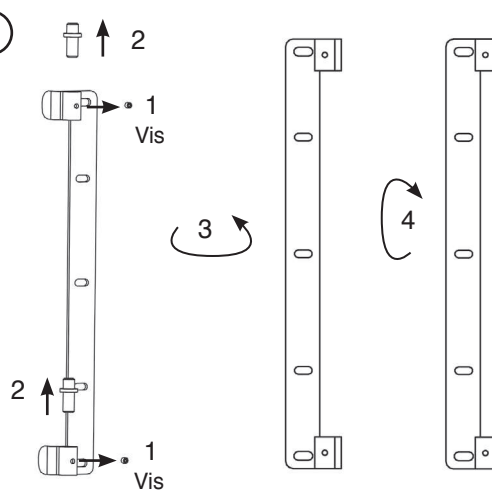

④

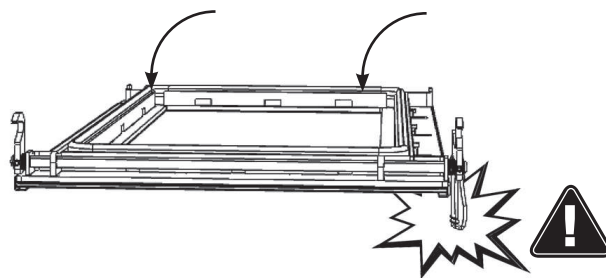
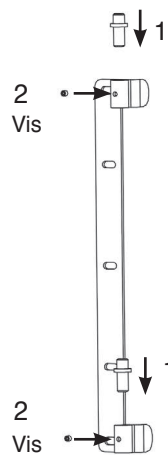

⑤

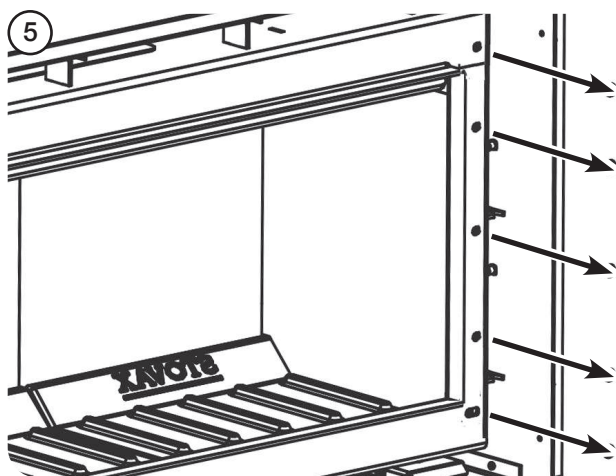

⑦

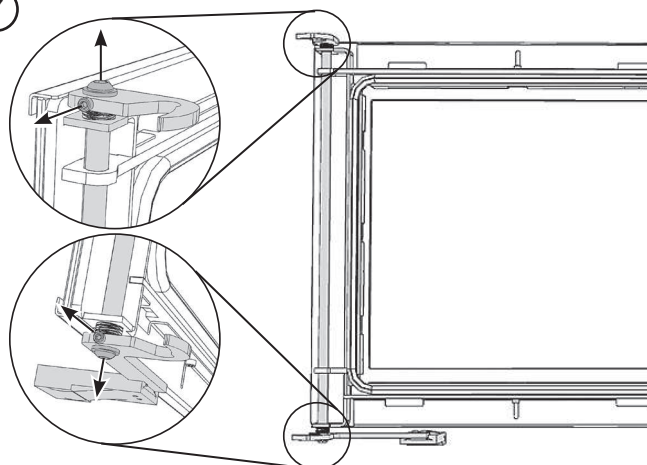

⑥

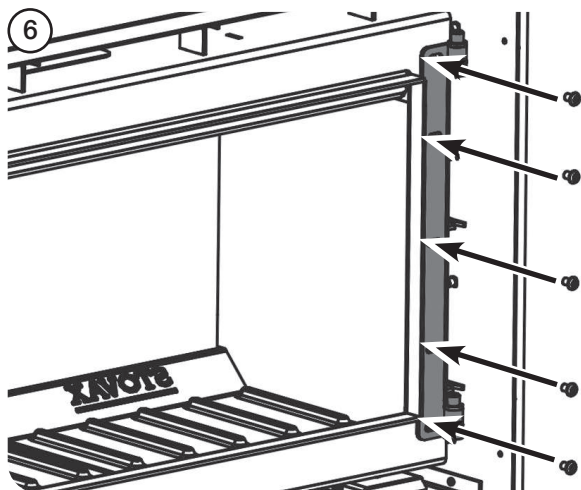

⑧

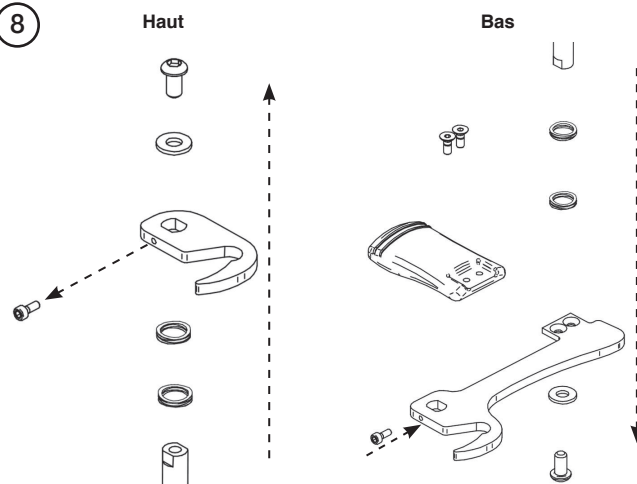

i Poser la porte avec la face vers le bas sur une surface plane molle pour protéger la peinture et la vitre.

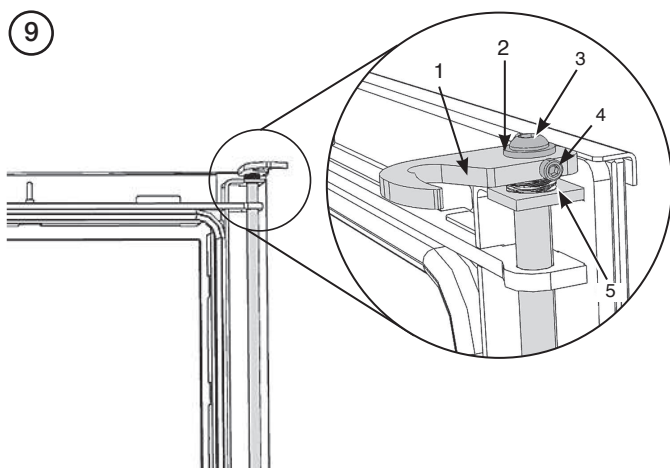

1. Crochet supérieur
2. Rondelle
3. Grande Vis
4. Petite Vis
5. 2x Ressorts

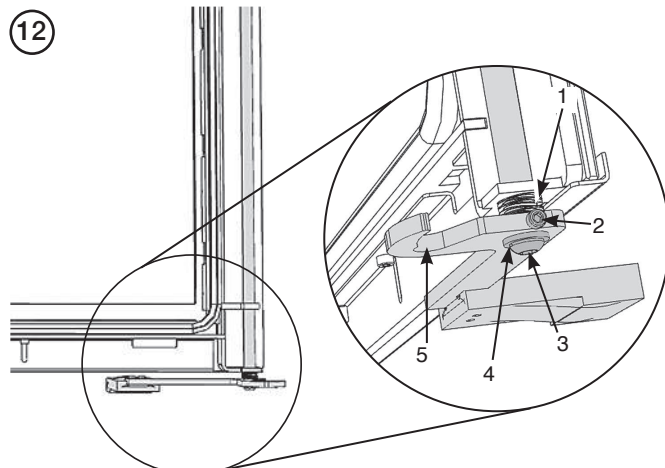

1. 2x Ressorts
2. Petite Vis
3. Grande Vis
4. Rondelle
5. Crochet inférieur

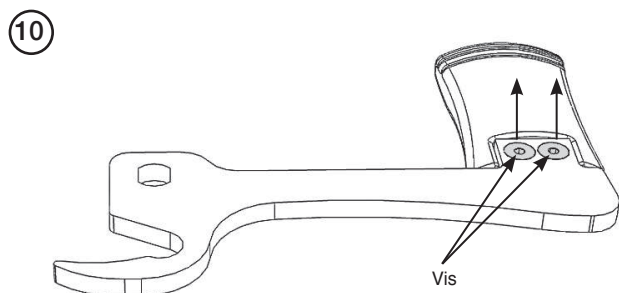

i Pour changer l'orientation de la porte, un loquet réversible de poignée de porte doit être acheté auprès de Stovax avant de commencer : Référence 326-929.
Conserver le loquet d'origine pour ramener la porte à son état initial.

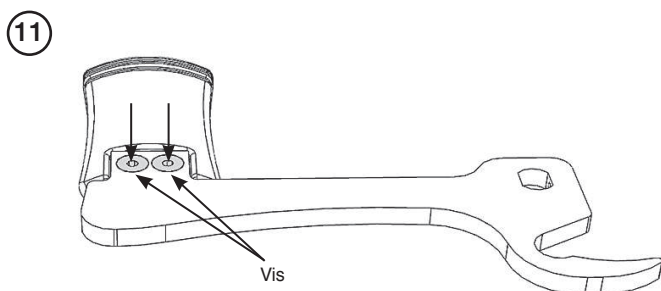

Taquets de la porte

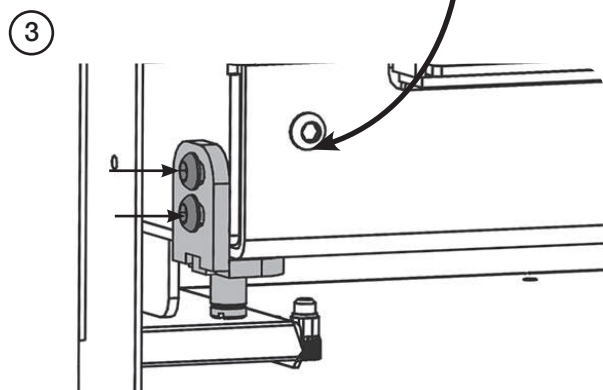
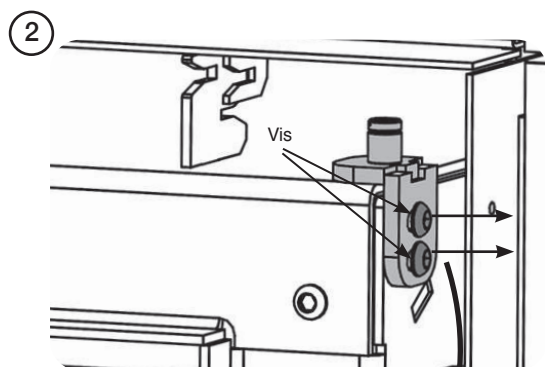
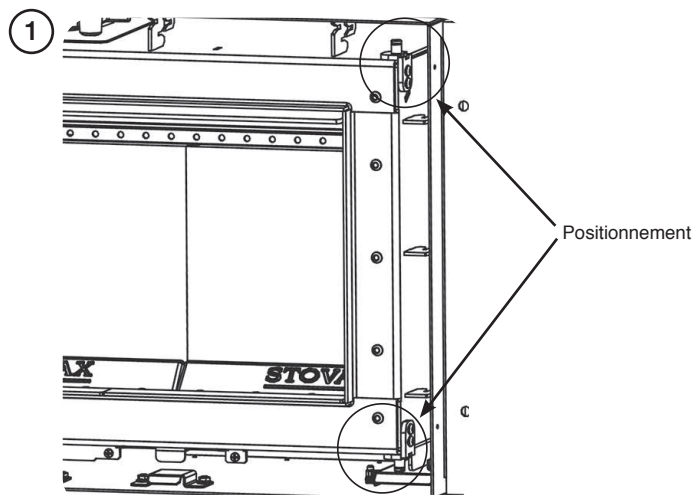

i Obturer les trous du côté opposé du boîtier à l'aide des vis ôtées auparavant.

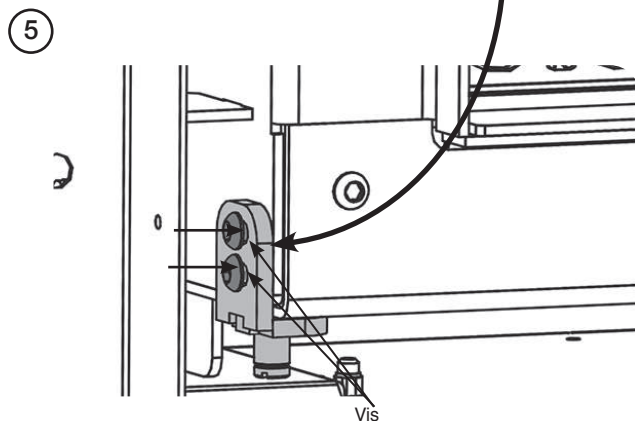
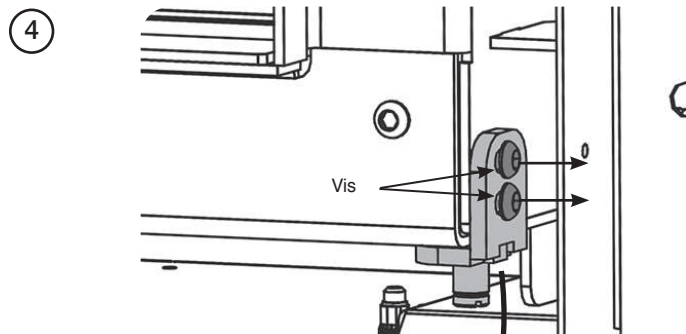

i Obturer les trous du côté opposé du boîtier à l'aide des vis ôtées auparavant.

Remonter la porte.

i Après inversion de la porte, il peut s'avérer nécessaire d'ajuster les charnières et les crochets pour une bonne fermeture de la porte en toute sécurité. La porte doit être à niveau du haut du boîtier interne et les crochets bien enclenchés. Voir Maintenance et Révision.

MISE EN SERVICE

Pour mettre l'insert en service :

- Remplacer tous les composants internes.
- Vérifier l'alignement de la porte et le bon fonctionnement du loquet, effectuer un réglage le cas échéant.
- Vérifier l'état des joints de porte, du corps de chauffe et des joints de l'appareil.

Effectuer maintenant le dernier essai de tirage :

- Préchauffer d'abord le conduit de fumée avec un chalumeau ou un autre instrument pendant environ 10 minutes.
- Placer un fumigène au centre de la grille et ouvrir les commandes d'air en grand.
- Fermer la porte. La fumée doit maintenant être aspirée dans le conduit et on doit la voir sortir par la cheminée.
- Compléter les essais avec toutes les portes et les fenêtres de la pièce où se trouve l'insert bien fermées.
- S'il y a des ventilateurs extracteurs dans les pièces adjacentes, les essais doivent être répétés alors que tous les ventilateurs marchent à la vitesse maximale et que les portes de communications sont ouvertes.
- Vérifier l'effet des ventilateurs de plafond pendant les essais.

En cas d'excès de fumée dans la pièce laisser l'insert refroidir complètement et inspecter à nouveau le conduit et la ventilation.

Finalement :

- Expliquer le fonctionnement sécurisé du poêle et l'utilisation des commandes d'air à l'utilisateur ainsi que l'importance de n'utiliser que des combustibles appropriés.
- Vérifier que le détecteur-avertisseur de CO a bien été installé et informer l'utilisateur de son fonctionnement et de son importance, en se reportant à la section Avertissement à la page 5 des Instructions d'utilisation.
- Expliquer la routine de nettoyage et de maintenance.
- Expliquer la nécessité d'utiliser un garde-feu pour la sécurité des enfants, des personnes âgées ou handicapées à proximité du poêle.
- Enregistrer les coordonnées du revendeur/ fournisseur et de l'installateur dans la liste des vérifications de la mise en service de l'appareil .
- Enregistrer le numéro de série dans la liste des vérifications de la mise en service de l'appareil.

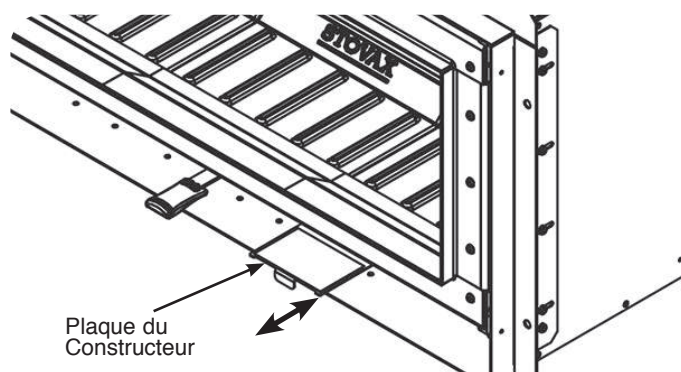

Ce numéro est requis lors de la commande de pièces de rechange ou de déclaration de sinistre aux termes de la garantie.

- Remettre l'exemplaire des Instructions au client.

ENTRETIEN

Pour obtenir une liste complète des pièces de rechange et des accessoires, contacter votre distributeur Stovax.

Avant le début de la saison de chauffage, démonter, inspecter et nettoyer l'appareil comme suit :

- Laisser l'appareil refroidir.
- Enlever tous les éléments internes : déflecteur, garde-bûches et briques réfractaires.
Faire attention lors de la manutention des briques car elles deviennent fragiles après une certaine période d'utilisation.
- Ramoner l'appareil à ce point le cas échéant.
- Utiliser un aspirateur pour enlever les cendres restantes et les débris de l'intérieur du poêle. Stovax propose un accessoire avec filtre pour enlever les cendres tout en protégeant l'aspirateur des braises éventuelles. (N° de pièce Stovax 2091).
- Vérifier que les éléments ne sont pas endommagés. Remplacer les éléments endommagés par des pièces de remplacement d'origine Stovax.
- Inspecter et nettoyer les briques réfractaires avec une brosse souple.
La surface peut être endommagée en cours d'utilisation. La durée de vie des briques dépend du type de combustible utilisé et de l'intensité d'utilisation.
Remplacer les briques endommagées dès que possible.
- Remettre les pièces internes nettoyées en place.
- **Utiliser le nettoyant vitres Stovax (Stovax n° 4103). Sa formule est mieux adaptée à cette opération.**
Ne pas utiliser de nettoyants abrasifs pour retirer les dépôts de goudron ou de suie de la vitre.
- Installer de nouveaux joints si besoin.
- Huiler légèrement le mécanisme du loquet de la porte et les gonds des charnières. Éviter de laisser tomber de l'huile sur les joints de porte et la vitre.
- Pour faire des retouches de peinture, une peinture pour retouches en aérosol est disponible.
Contactez votre détaillant Stovax en mentionnant le numéro de série qui se trouve sur la fiche signalétique de l'appareil.

Utiliser des pièces de rechange Stovax authentiques pour garantir le bon rendement du poêle en toute sécurité.
Voici une liste des produits de maintenance dont vous pouvez avoir besoin.

Les produits de nettoyage et d'entretien de votre Studio Air sont disponibles en ligne sur www.stovax.fr ou auprès de votre détaillant Stovax et, outre l'entretien régulier et l'usage des bons combustibles, garderont l'appareil dans la meilleure condition possible.

Pour de plus amples informations sur les produits du groupe Stovax, consulter notre site Internet <http://www.stovax.fr>.

Faire fonctionner l'appareil à basse température pour le premier jour d'utilisation après toute maintenance. Ceci permet aux joints, aux adhésifs et à la peinture de bien sécher.

Pendant cette période, la surface de l'appareil émet des odeurs déplaisantes. S'assurer que la pièce est bien ventilée pour éviter l'accumulation de vapeurs.

Le distributeur Stovax peut effectuer les révisions et la maintenance.

i **IMPORTANT:**
Stovax fournit des gants avec manchette pour que l'utilisateur soit protégé de la chaleur et des côtés saillants de l'appareil.
Pour votre sécurité assurez-vous de toujours utiliser les gants lors de l'ouverture, l'utilisation, le rechargement ou la manipulation des composants de l'appareil.

TÂCHE	CODE PRODUIT	NO.
Prévention de l'accumulation de créosote dans le conduit	Protecteur (15 sachets)	7002
	Protecteur (Tube 1 kg)	7025
Scellement des joints de conduit	Ciment réfractaire (Tube 500 g)	2024
	Ciment réfractaire (Cartouche 600g)	2021
Retouches de peinture	Retouchez aérosol (150ml aérosol)	2056
Protection des mains	Gant en cuir résistant à la chaleur	4008 4027 - Long
Adhésif de joint thermique	(50ml bottle)	5037
Nettoyage De La Vitre	Stovax nettoyeur de vitre	4103
Accessoire d'aspirateur	Accessoire d'aspirateur	2091M

REPLACEMENT DU JOINT DE PORTE

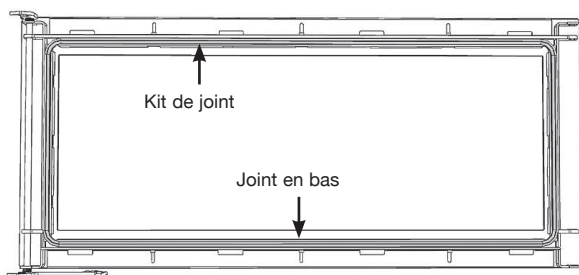
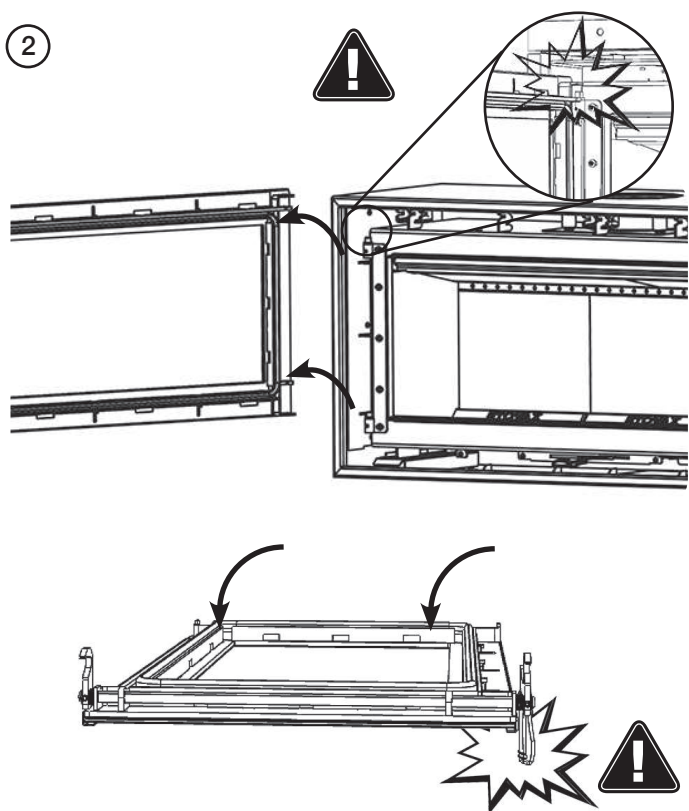
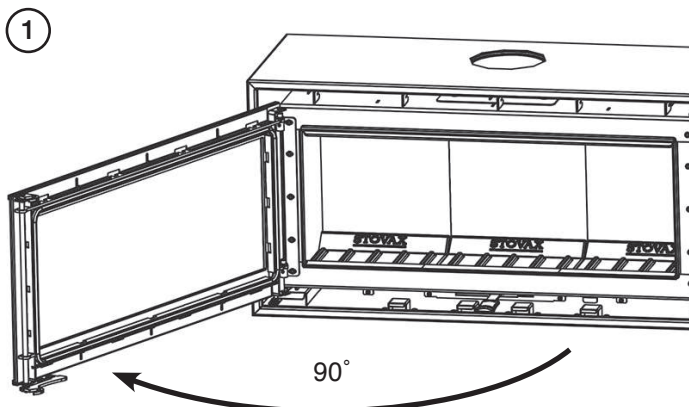

Pour s'assurer du fonctionnement continu du poêle en toute sécurité, il faut remplacer les joints de porte endommagés ou usés. Pour terminer cette opération, retirez la porte. Retrait de la porte de la section concernant la pré-installation.

Retirer le joint et racler la colle pour la retirer de la goulotte. Nettoyer la goulotte à l'aide d'un chiffon propre et sec pour retirer la poussière et les débris.

Étaler un bourrelet généreux de colle de joint thermique Stovax dans la goulotte.

Enfoncer le nouveau joint Stovax dans la goulotte, en plaçant le joint au milieu du bord supérieur de la porte. Utiliser le ruban adhésif fourni aux extrémités.

Remettre la porte en place et la fermer pour appliquer une pression sur le nouveau joint.

Laisser la porte fermée pendant au moins 12 h avant d'allumer le poêle et de le laisser brûler à une puissance modérée pendant environ une journée.

L'utilisation de l'insert alors que le joint de porte est endommagé peut laisser des gaz de combustion dangereux se répandre dans la pièce ou causer une combustion excessive et des dommages dus à la surchauffe de l'insert.

RÉGLAGE DES CHARNIÈRES DE PORTE

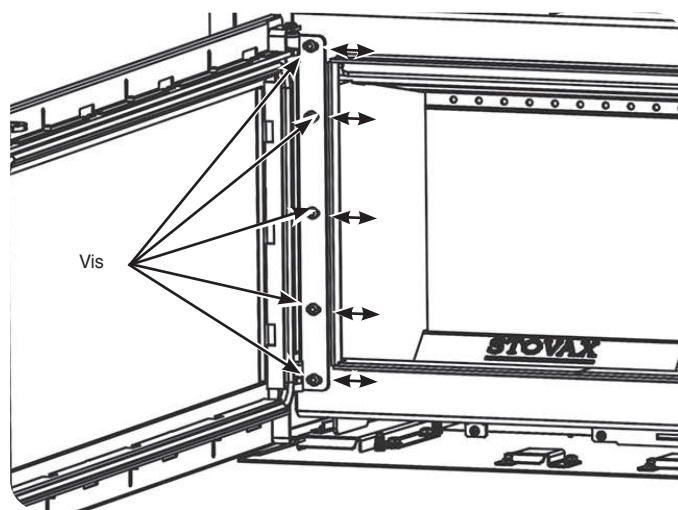

Afin de maintenir une utilisation sécurisée de votre appareil, il se peut que vous ayez à régler les charnières de la porte de manière à assurer la fermeture correcte et sécurisée de la porte. La porte doit être horizontale / de niveau avec le haut du corps de chauffe et le loquet de la porte engagé correctement.

Il est possible d'ajuster à l'aide des charnières du boîtier interne. Ouvrir la porte pour accéder.

Charnières sur le boîtier interne

Desserrer les vis dans l'appareil comme sur la figure. C'est destiné à l'ajustement horizontal. Il est parfois nécessaire d'effectuer cette démarche plusieurs fois pour arriver à la bonne position.

La porte doit être à niveau.

RÉGLAGE DU LOQUET DE LA PORTE

Pour maintenir une utilisation sécurisée de votre appareil, il se peut que vous ayez à régler le loquet de la porte de manière à obtenir une bonne fermeture de la porte. Si les charnières de la porte ont été réglées, le loquet de la porte demande à être ajusté.

Les schémas montrent le réglage d'une porte avec des charnières à gauche. Si la porte a été inversée, la méthode reste identique.

Les crochets sont situés en haut et en bas du côté ouvert de la porte.

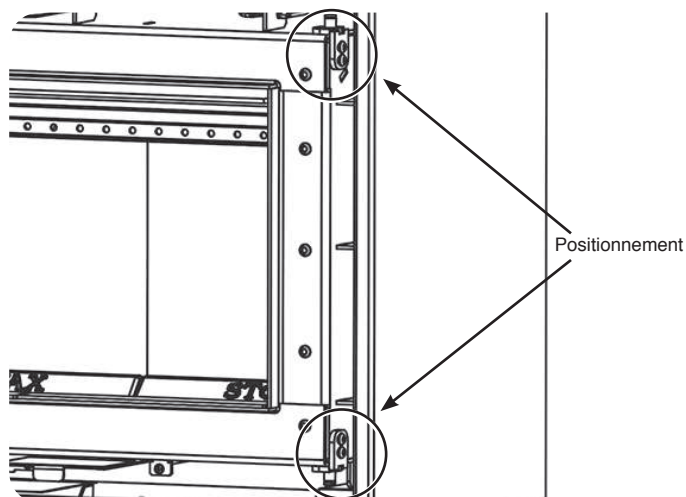

Bloc d'accroches supérieures

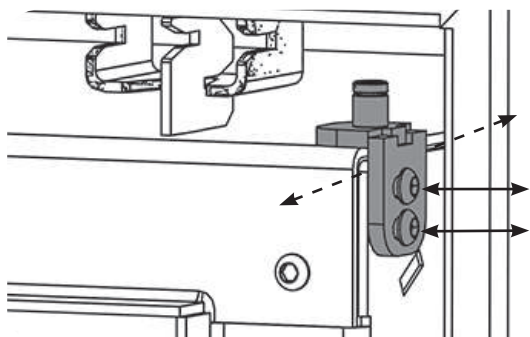

Bloc d'accroches inférieures

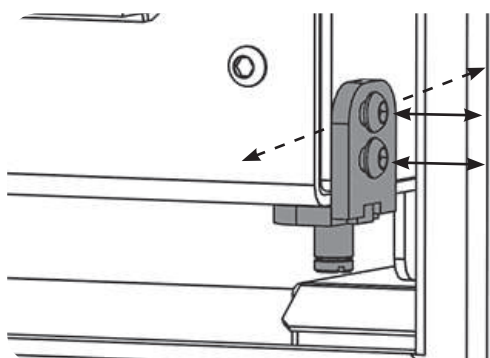

Le serrage ou desserrage de la vis M6 et des écrous sur le bloc du loquet déplace le loquet vers l'intérieur ou l'extérieur à partir de la porte et permet au crochet de mieux agripper les rouleaux de la porte.

Ne pas retirer la vis ou les écrous complètement.

EFFECTUER UN TEST PAPIER

Pour effectuer un test papier, coincer une feuille de papier dans la porte au niveau des cotés de manière à vérifier que le joint de porte empêche bien l'air d'entrer dans l'appareil. Si le papier peut être tiré facilement, l'étanchéité est alors insuffisante et le cordon doit être remplacé.

Répéter cette opération sur tous les cotés de l'appareil.

FICHE PRODUIT - INFORMATIONS À FOURNIR POUR UN APPAREIL DE CHAUFFAGE À COMBUSTIBLE SOLIDE

Modèle	Studio Air 1	Studio Air 2
Classe Energie	A+	A
Puissance calorifique directe (kW)	6.2	8.2
Puissance indirecte (kW)	-	-
Indice d'efficacité énergétique (IEE)	109	105
Rendement à la puissance calorifique nominale	81.4%	78.5%
Précautions de sécurité	L'appareil doit être installé, utilisé et entretenu conformément aux instructions du fabricant fournies	

INFORMATIONS MATÉRIELLES DU PRODUIT

Les substances, préparations ou composants suivants doivent être éliminés ou revalorisés séparément des autres DEEE, conformément à l'article 4 de la Directive 75/442/CEE du Conseil de l'Union européenne.

Métal	Acier	Vous pouvez remettre ces éléments à votre centre de recyclage local pour les réutiliser et réduire le volume de déchets envoyés dans les sites d'enfouissement.
	Fonte	
Verre		Vous pouvez remettre ces éléments à votre centre de recyclage local pour les réutiliser et réduire le volume de déchets envoyés dans les sites d'enfouissement.
Revêtement en vermiculite		Matériau non dangereux. La vermiculite peut être broyée et utilisée comme substrat pour vos plantes tandis que les cendres peuvent être utilisées comme compost ou remises à votre centre de recyclage local pour les réutiliser et réduire le volume de déchets envoyés dans les sites d'enfouissement.
Tresses d'étanchéité		Les joints d'étanchéité sont fabriqués en fibres céramiques réfractaires (FCR), un matériau couramment utilisé dans ce type d'application. Nul besoin d'utiliser des vêtements de protection lorsque vous manipulez ces articles, toutefois il est recommandé de suivre les règles d'hygiène habituelles, c'est-à-dire ne pas fumer, ni manger ni boire sur le lieu de travail et toujours se laver les mains avant de manger ou de boire. Lorsque vous réalisez l'entretien de l'appareil, nous vous recommandons de ne pas briser les pièces remplacées mais plutôt de les mettre dans un sac en polythène ultrarésistant, scellé et portant l'étiquette « déchets FCR ». Les déchets FCR sont catégorisés comme des déchets dangereux stables et non réactifs, et peuvent être mis au rebut dans un site d'enfouissement agréé.
Composants électriques	(Kits de ventilateur, etc., le cas échéant)	Mettez-les au rebut dans votre centre de recyclage local, conformément à la directive DEEE.

INFORMAZIONI GENERALI

Installazione Dell'apparecchio

Ogni installazione è unica per la struttura, quindi non è possibile fornire dettagli adatti ad ogni caso.

L'installazione deve soddisfare le normative edilizie e deve essere effettuata utilizzando i metodi di costruzione stabiliti nelle "migliori procedure".

Prestare attenzione durante l'installazione dell'apparecchio. Una manipolazione non accurata e l'utilizzo di strumenti possono danneggiare la rifinitura e/o l'area.

Posizionamento dell'apparecchio

Molte aperture per i caminetti hanno un architrave di sostegno. Non rimuovere senza sostenere la struttura restante dell'edificio. Non sostenere la struttura con apparecchio o il sistema della canna fumaria.

Nel caso venisse montato un kit per la presa d'aria esterna vanno consultati manual PM1690 prima dell'installazione.

Professionista registrato:

Prima dell'installazione e/o dell'utilizzo dell'apparecchio leggere attentamente le presenti istruzioni nella loro integrità per assicurarsi di comprendere tutte le indicazioni in esse contenute.

L'apparecchio deve essere montato da un installatore certificato o approvato dal funzionario locale addetto al controllo degli edifici.

Supporto strutturale:

In caso di installazione su un pavimento in legno verificare che i travetti del pavimento siano abbastanza resistenti da sostenere il peso dell'inserto, della canna fumaria e delle parti costruttive.

Focolare:

Occorre installare un focolare di costruzione profondo 125 mm e la relativa piastra decorativa da 12 mm per proteggere un pavimento infiammabile dall'eventuale caduta di braci in caso di montaggio direttamente sul pavimento.

Il focolare decorativo deve estendersi per 300 mm davanti al focolare ed essere realizzato in pietra naturale, cemento, metallo o vetro.

Ispezione finale dell'installazione:

Una volta installato, l'apparecchio deve essere messo in funzione in conformità agli standard e alle pratiche per assicurare un perfetto funzionamento e una consegna corretta al cliente.

Canale da fumo e canna fumaria

Il canale da fumo o la canna fumaria devono essere in grado di sopportare temperature interne fino a 400°C.

Il diametro esterno del manicotto di collegamento è 155 mm.

In modalità di funzionamento normale, il tiraggio dovrebbe essere di 20-25 Pa in prossimità del manicotto di collegamento. Sul tiraggio influiscono principalmente la lunghezza e l'area della canna fumaria oltre al suo grado di tenuta.

La lunghezza minima consigliata della canna fumaria è 3,5 m e la sua sezione trasversale ideale è di 150-200 cm² (diametro di 140-160 mm). Curve strette e tratti orizzontali nel canale da fumo riducono il tiraggio nella canna fumaria.

Deve essere possibile pulire il canale da fumo per tutta la sua lunghezza e gli sportelli di ispezione della fuliggine devono essere facilmente accessibili.

Verificare che la canna fumaria sia sigillata e che il fumo non fuoriesca dai collegamenti.

Erogazione dell'aria di combustione

Una volta installato l'apparecchio, è fondamentale garantire un'adeguata erogazione d'aria nell'ambiente. L'aria può essere immessa indirettamente tramite una presa d'aria nella parete esterna o un condotto esterno collegato al manicotto sul lato inferiore dell'inserto. È necessario un volume di aria di combustione di circa 20 m³/ora. Il diametro esterno del manicotto di collegamento dell'aria di combustione è 80 mm.

Se il condotto è lungo più di 1 m, il suo diametro deve essere portato a 100 mm e occorrerà una presa d'aria più grande sulla parete.

Negli ambienti riscaldati, il canale da fumo deve essere isolato per evitare la condensa utilizzando lana di roccia da 30 mm rivestita da una barriera vapore. Il foro nella parete (o nel pavimento) nel punto di uscita deve essere correttamente sigillato con un sigillante per canali da fumo. È disponibile un tubo flessibile per fornire aria esterna direttamente nell'apparecchio che deve essere montato durante l'installazione.

Allarmi di monossido di carbonio

Tutte le stufe dotate di canna fumaria aperta risentono delle condizioni atmosferiche temporanee, che possono determinare l'ingresso dei fumi all'interno della stanza. Ulteriori indicazioni sull'installazione del rilevatore di monossido di carbonio sono disponibili nella versione più recente della disciplina BS EN50292 e nelle istruzioni del produttore del sistema.

La presenza di un allarme non deve essere considerata una soluzione in grado di sostituire un'installazione corretta della stufa o la manutenzione e la riparazione periodiche della stufa e del sistema della canna fumaria.

DIMENSIONI

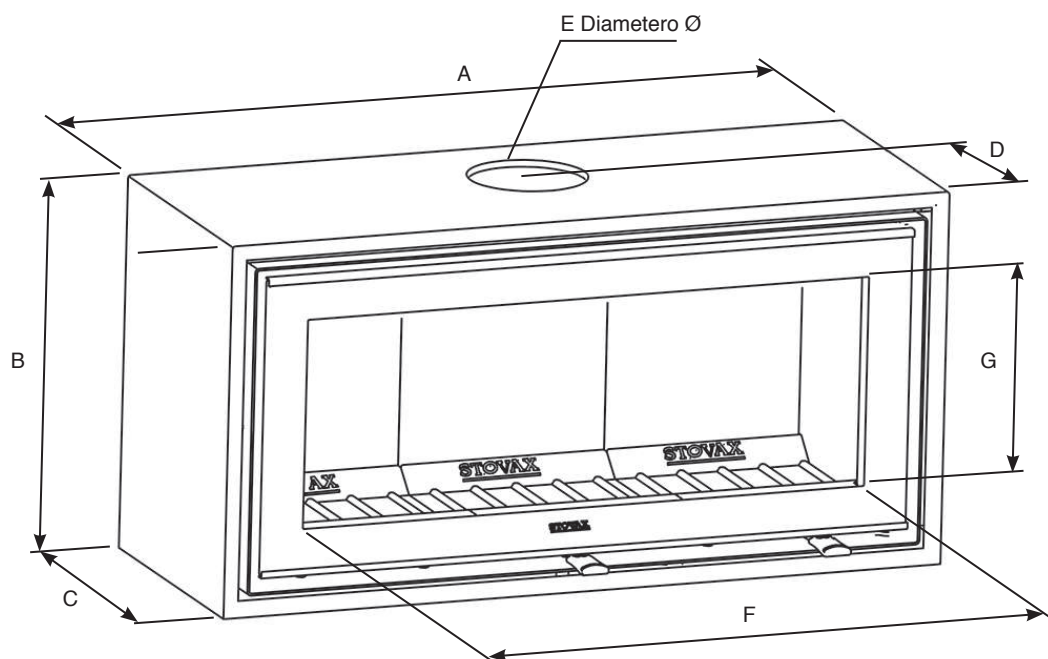

	A	B	C	D	E	F	G
Studio Air 1	809	481	382	234	152	590	259
Studio Air 2	1009	506	382	234	152	790	284

Tutte le dimensioni in mm

VENTILAZIONE ESTERNA

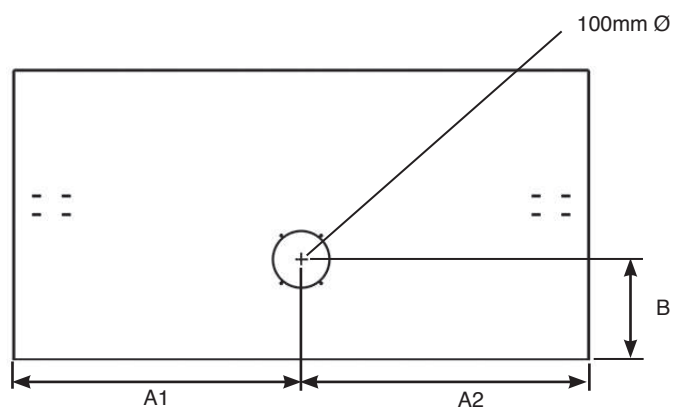

	A1	A2	B
Studio Air 1	404.5	404.5	174.5
Studio Air 2	504.5	504.5	174.5

DISTANZE DA MATERIALI COMBUSTIBILI

CONFIGURAZIONE CHIUSA

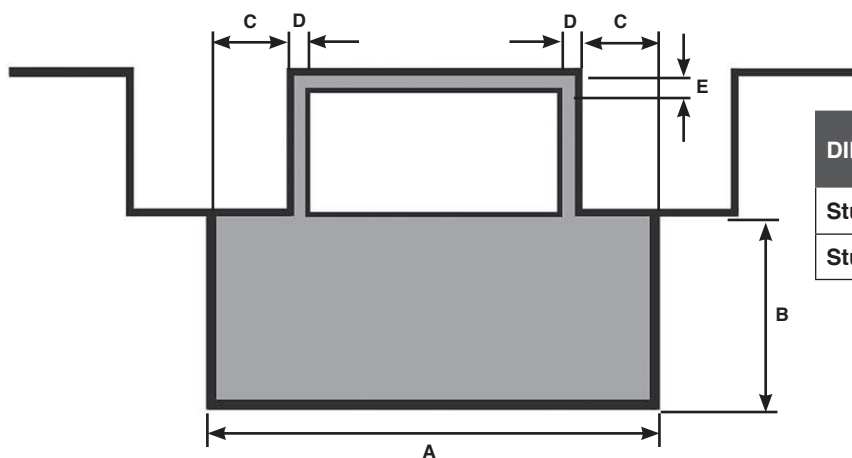

DIMENSIONI (MM)	A	B	C	D	E
Studio Air 1	1309	500	250	50	125
Studio Air 2	1609	700	300	50	125

CONFIGURAZIONE APERTA

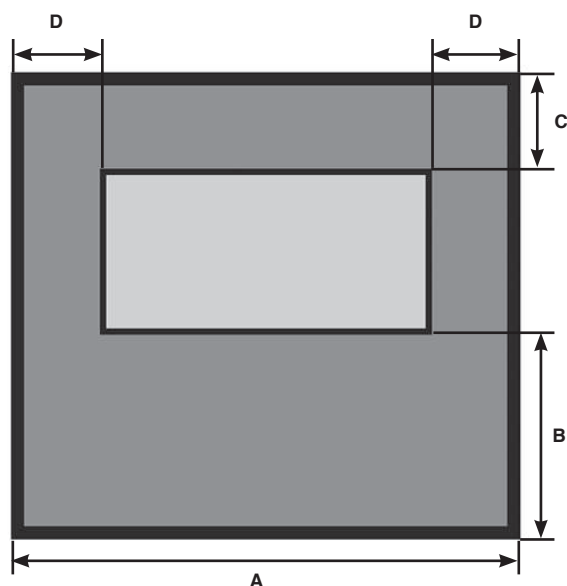

DIMENSIONI (MM)	A	B	C	D
Studio Air 1	1309	500	125	150
Studio Air 2	1609	700	125	180

ALTEZZA FINO ALLA CAPPA

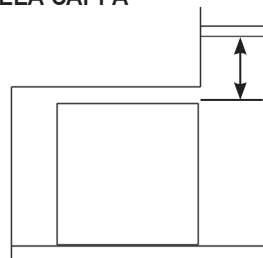

DIMENSIONI (MM)	HAUTEUR
Studio Air 1	500
Studio Air 2	800

SPESSORE DEL FOCOLARE

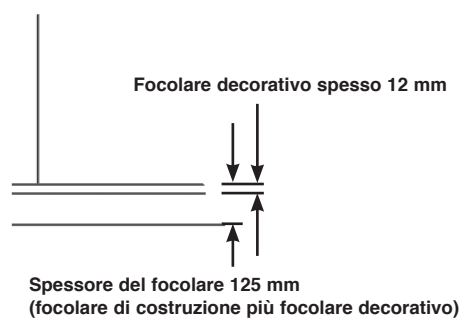

Se questo apparecchio è installato su una panchina STOVAX, il banco può rappresentare su un focolare non combustibile di 12 mm di spessore e si consiglia di aumentare la profondità del focolare da 225 mm per contenere in sicurezza i registri o le braci cadenti.



*Stovax consiglia che la profondità del Focolare Decorativo sia uguale o maggiore dell'altezza dell'apparecchio dal pavimento, OPPURE, della lunghezza dello sportello dalla parete quando è in posizione aperta. SCEGLIERE IL NUMERO MAGGIORE TRA I DUE.

DISTANZA RISPETTO AL MATERIALE NON INFIAMMABILE

DISTANZE DI SICUREZZA DELLA POSIZIONE PARALLELA

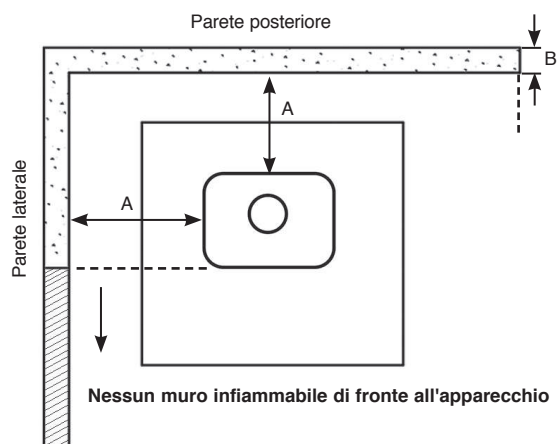

SPESSORE DEL FOCOLARE

Spessore del focolare 125 mm (focolare di costruzione più focolare decorativo).

DISTANZA DA MATERIALI NON COMBUSTIBILI		
Distanza dell'apparecchio alla parete (A)	Spessore minimo della parete (B)	Altezza minima della parete (C)
0mm - 50mm	200mm	Altezza dell'apparecchio + 300mm O 1200mm dal focolare (scegliere la dimensione maggiore)
51mm - 300mm	75mm	
300mm+	Nessun requisito	Nessun requisito

Hauteur au-dessus de l'appareil

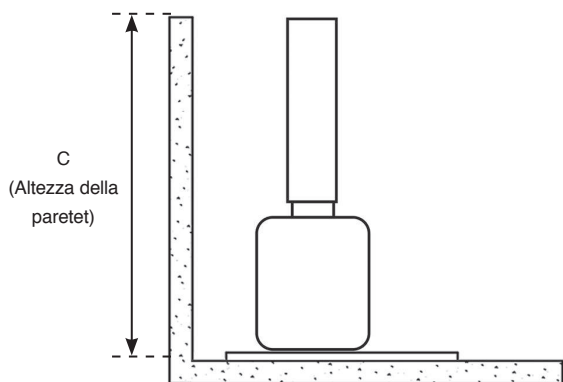

DISTANZE DI SICUREZZA DELLA POSIZIONE AD ANGOLO

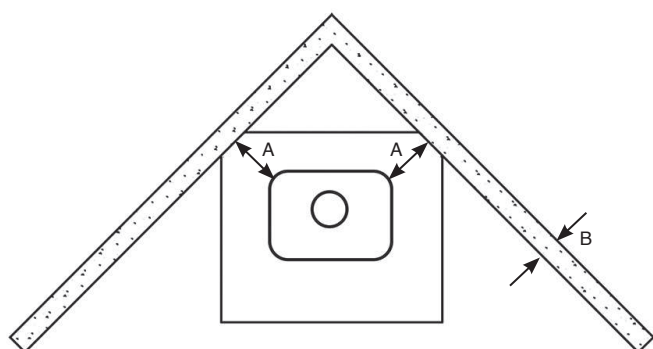

NUMERO IDENTIFICATIVO DELLE PARTI

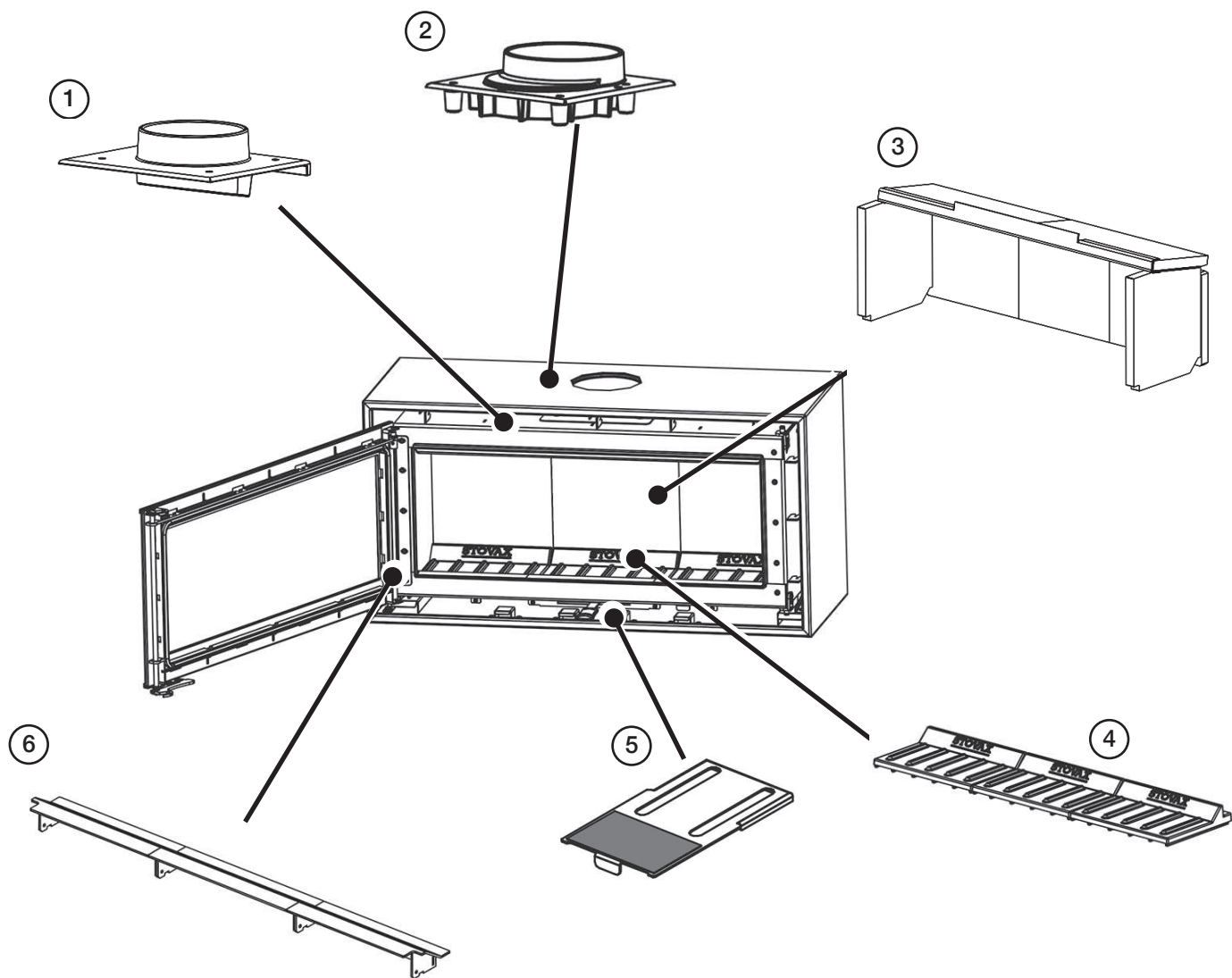

1. Flangia di scarico interna
2. Flangia di scarico superiore
3. Mattoni per pareti interne e set dilamiere
4. Mattoni per la base
5. Targhetta identificativa
6. Protezione per ceppi

INFORMAZIONI IMPORTANTI

GENERALI	Modello::			Studio Air 1	Studio Air 2
	Rendimento calorico nominale	Legno	kW	5.0	8.2
	Efficienza	Legno	%	79.6	78.5
	CO @ 13% O ₂	Legno	%	0.12	0.08
	Peso		Kg	123	165
Combustibili Consigliati		Legno	Legno stagionato (umidità inferiore al 20%)		

Sottoposto a collaudo in base alla normativa EN 13240 per combustione con funzionamento intermittente.

CANNA FUMARIA	Dimensione della canna fumaria/del camino	Con rivestimento o sistema prodotto in fabbrica (diametro) <small>installato in conformità alle istruzioni del produttore</small>	mm	153	153
	Canna fumaria/camino (altezza minima)	Tutti i prodotti	m	4.5	4.5
	Tiraggio canna fumaria	Minimo	Pa	10	10
		Nominale		12	12
		Massimo		20	20
	Flusso di massa del gas della canna fumaria	Legno	g/s	4.7	6.5
	Temperatura gas canna fumaria al raccordo/presa	Legno	°C	261	304
Diametro uscita canna fumaria (opzione parte superiore)		mm	153	153	

Specifiche minime europee per le canne fumarie - T400 N2 D 3 G50

VENTILAZIONE	A) Case di vecchia costruzione		B) Case di nuova costruzione		
	• Se la ventilazione è superiore a 5 m ³ /ora/m ² .		• Se la ventilazione è inferiore a 5 m ³ /ora/m ² .		
	• Ventilazione normalmente richiesta = 550 mm ² per una potenza kW superiore a 5 kW		• Ventilazione normalmente richiesta = 550 mm ² per kW		
	A	Ventilazione Aggiuntiva	mm ²	Nessuna	1760
			cm ²	Nessuna	17.6
	B	Ventilazione Aggiuntiva	mm ²	2750	4510
cm ²			27.5	45.10	

PRE-INSTALLAZIONE

Per semplificare l'installazione della stufa, rimuovere i componenti interni prima di integrarli nella bocca del camino/nell'intelaiatura di sostegno.

SPORTELLO

①

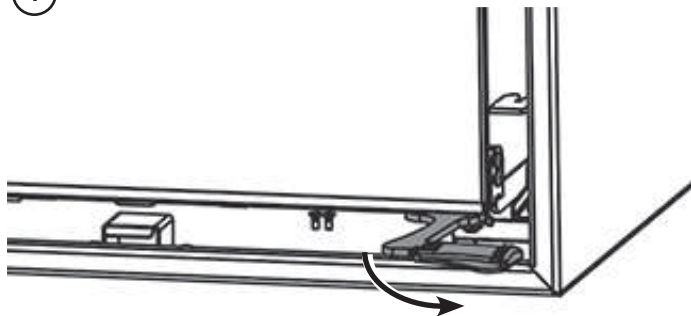

②

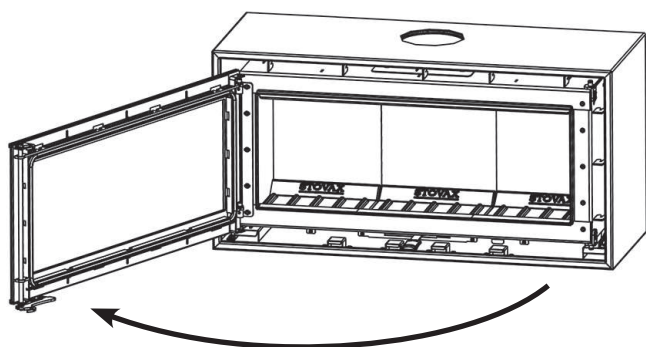

PROTEZIONE PER CEPPI

Non utilizzare l'apparecchio senza le protezioni per ceppi.

①

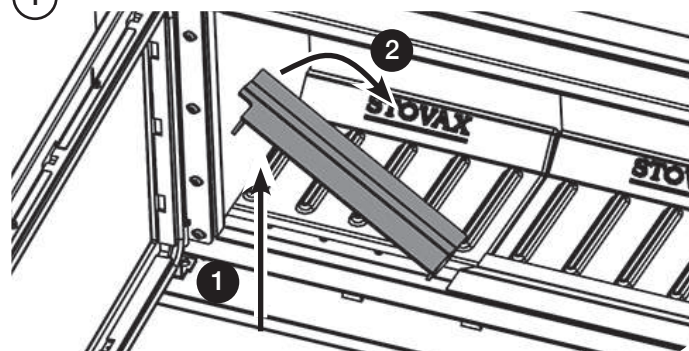

②

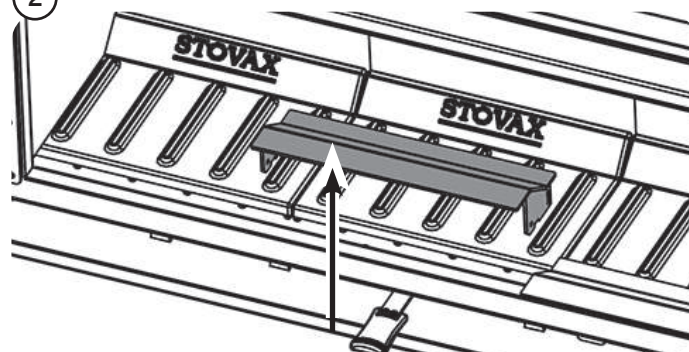

③

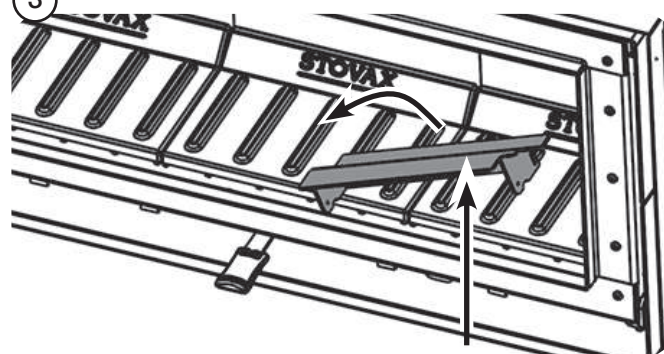

Sono in dotazione le protezioni per ceppi sinistra e destra. Le fessure devono essere posizionate sul lato della scatola di combustione rivolte in avanti



MATTONI REFRATTARI E DEFLETTORE

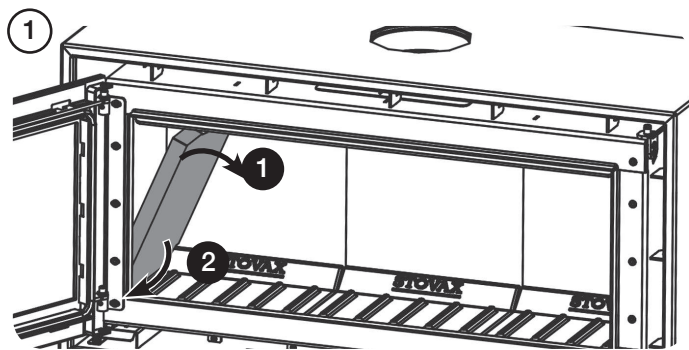

Barra della lamiera di supporto

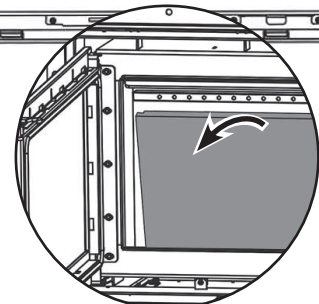
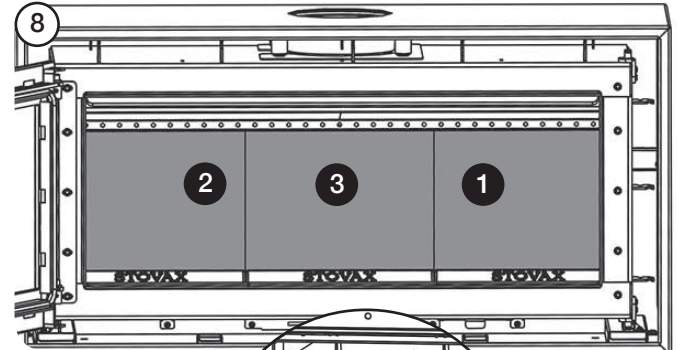
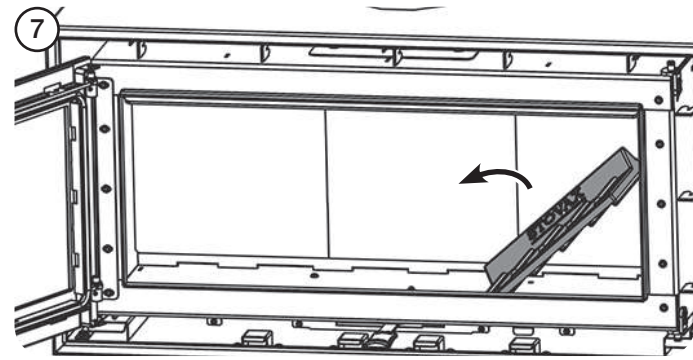
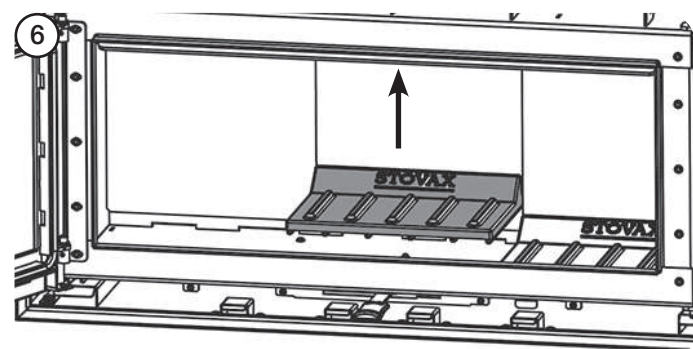
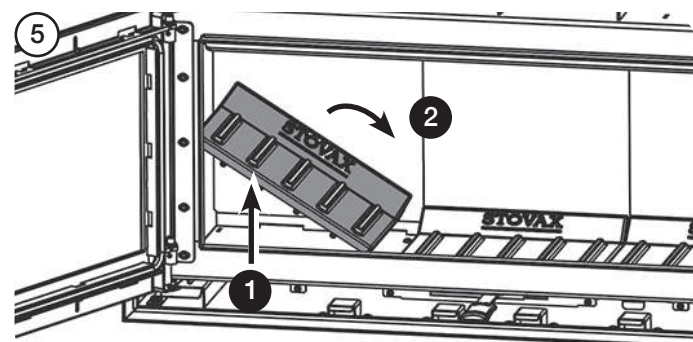
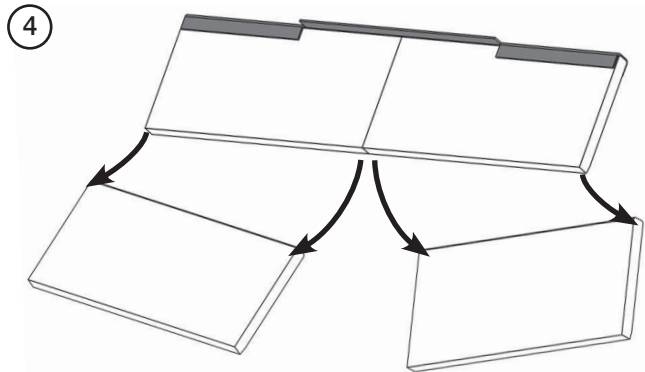
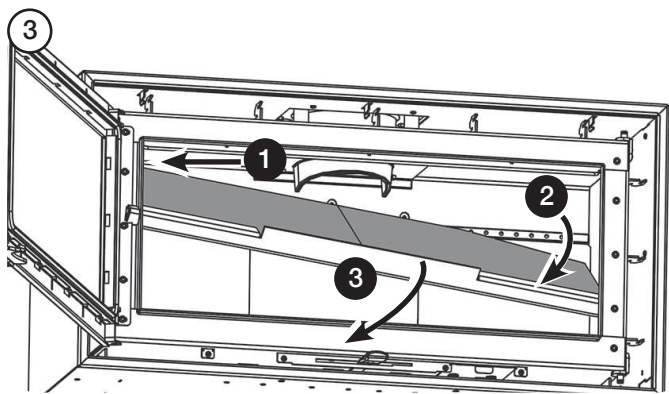
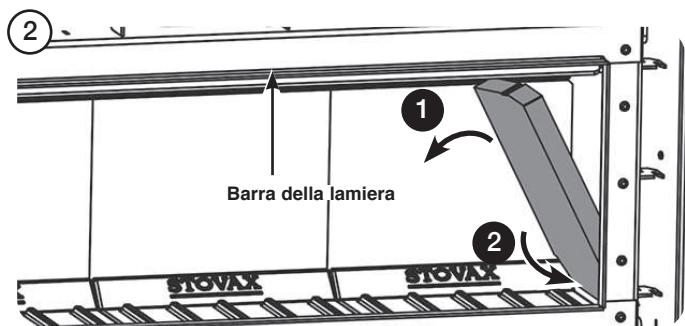

ANELLO INTERNO

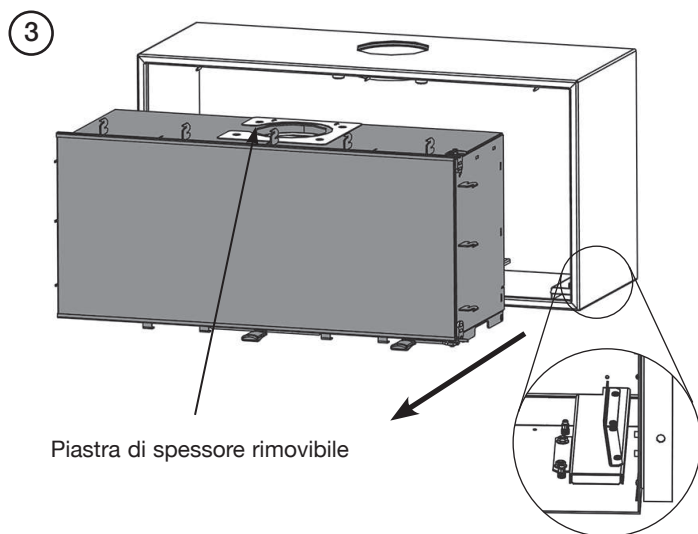
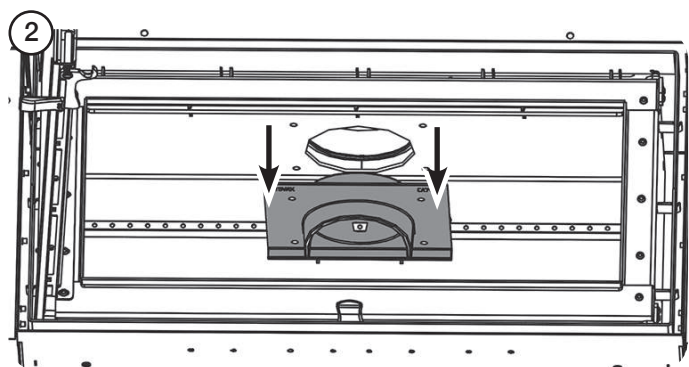
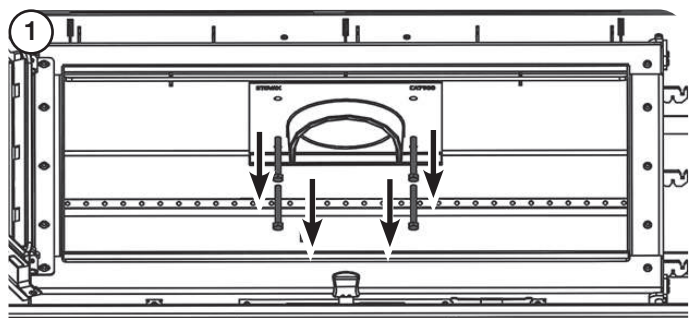

RIMOZIONE DEL COLLARE ESTERNO

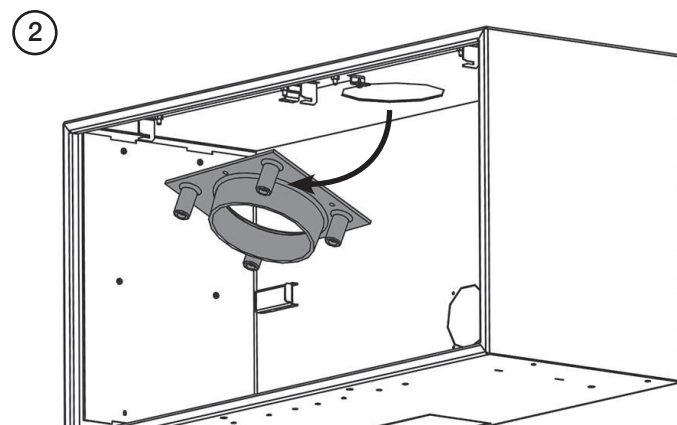
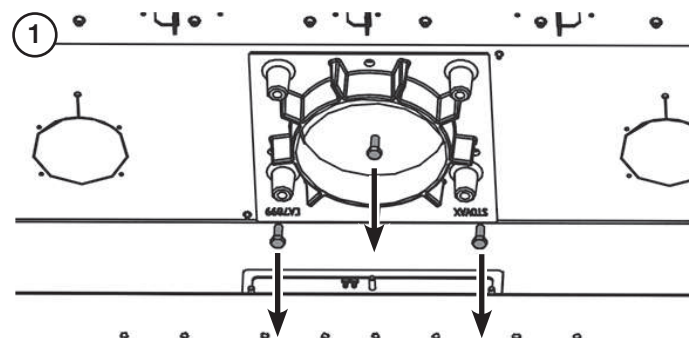
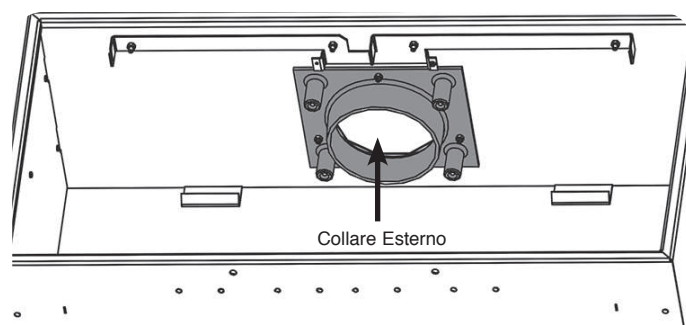

I bulloni vanno inseriti in una staffa sulla sommità della scatola esterna.
Tutto ciò resta montato quando si installa il sistema del canale da fumo.

INSTALLAZIONE

INSTALLAZIONE DELL'APPARECCHIO

Ogni installazione è unica per la struttura, quindi non è possibile fornire dettagli adatti ad ogni caso. L'installazione deve soddisfare le normative edilizie e deve essere effettuata utilizzando i metodi di costruzione stabiliti nelle "procedure migliori".

Molte aperture per i caminetti hanno un architrave di sostegno. Non rimuovere senza sostenere la struttura restante dell'edificio. **Non sostenere la struttura con apparecchio o il sistema della canna fumaria.**

Prestare attenzione durante l'apparecchiatura. Una manipolazione non accurata e l'utilizzo di strumenti possono danneggiare la rifinitura e / o l'area.



NOTA: Nel caso venisse montato un kit per la presa d'aria esterna vanno consultati manual PM1690 prima dell'installazione.

ACCESSORI OPZIONALI

I seguenti optional possono migliorare le prestazioni dell'apparecchio e devono essere montati al momento dell'installazione.

COPERCHIO CANNA FUMARIA DECORATIVO

Questo prodotto può essere installato con una copertura della canna fumaria decorativa. Per le procedure di installazione, fare riferimento alle istruzioni fornite con il kit.

KIT DI CONDOTTI DI CONVEZIONE DELL'ARIA

Questo apparecchio può essere dotato di un kit opzionale di condotti di convezione dell'aria per favorire la circolazione dell'aria calda ad altri ambienti della casa. Questa funzionalità potrebbe richiedere un'ulteriore ventilazione in conformità alle normative edilizie. Prima dell'applicazione è necessario rivolgersi ad un installatore qualificato.

PANCA

Questo prodotto può essere dotato di un banco. Il montaggio deve essere effettuato al momento dell'installazione. Fare riferimento alle istruzioni.

INSTALLAZIONE

Prestare attenzione durante l'installazione dell'apparecchio. Una manipolazione non accurata e l'utilizzo di strumenti possono danneggiare la rifinitura e/o l'area.

FISSARE L'APPARECCHIO AL FOCOLARE CON BULLONI

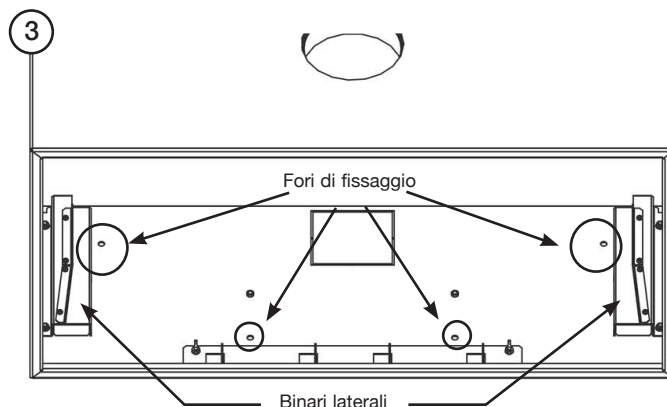
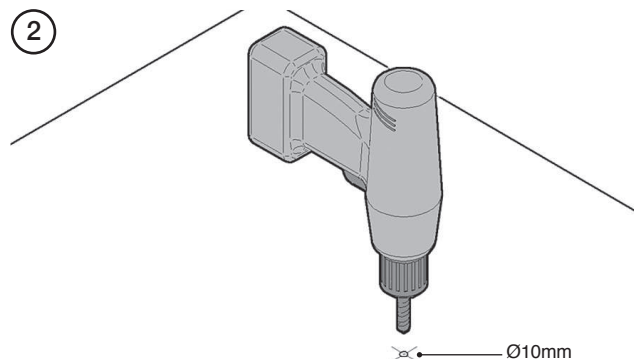
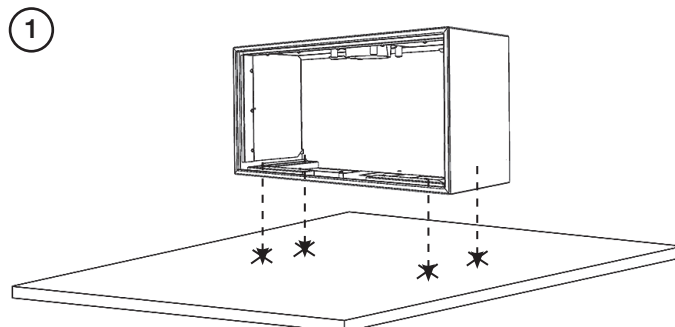

La scatola esterna può essere rimontata solo con il cursore dell'aria in posizione centrale.

RIMONTAGGIO DELLE FLANGE DI SCARICO

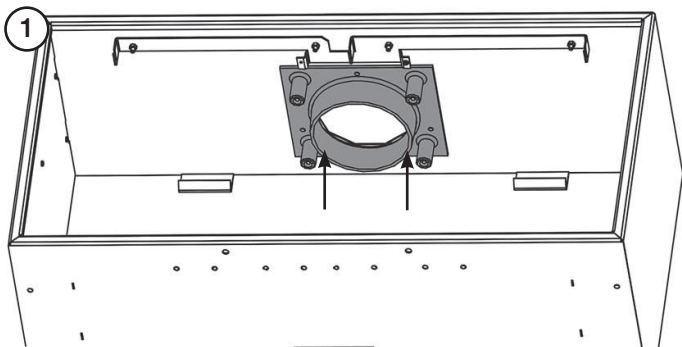

Montare in maniera allentata i bulloni corti (1) poi montare i bulloni più lunghi (2).

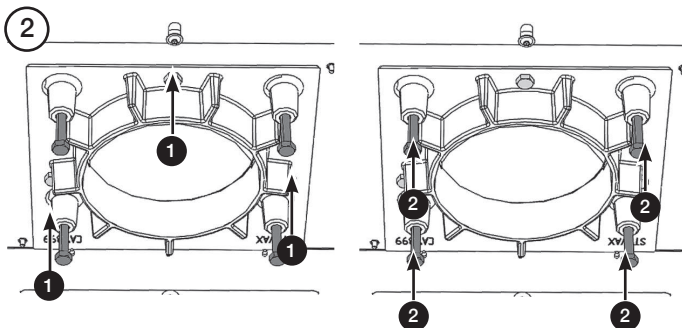

Serrare i bulloni corti.

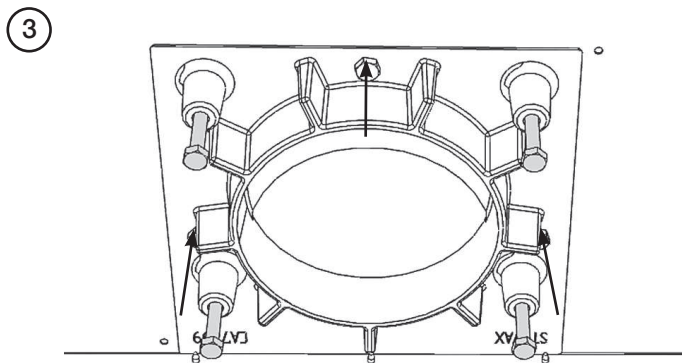

Rimuovere i bulloni più lunghi.

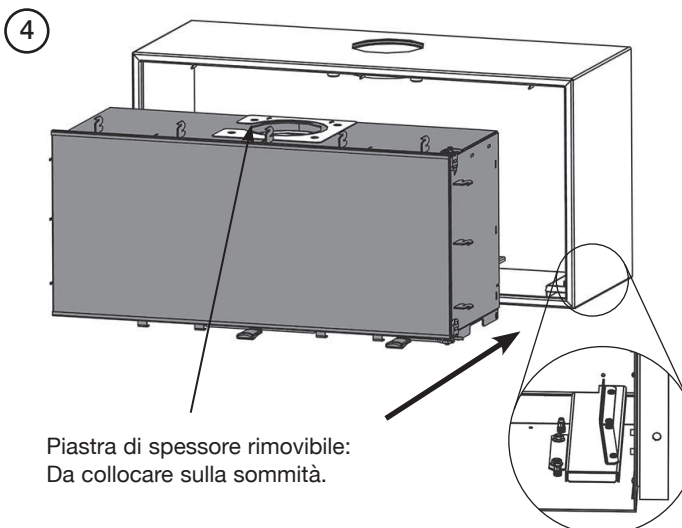

Piastra di spessore rimovibile:
Da collocare sulla sommità.

5 Collare interno della canna fumaria

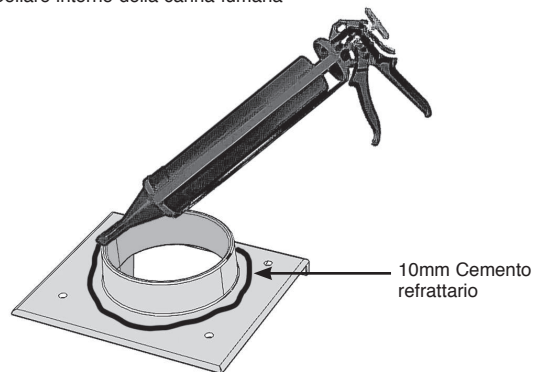

6 Scatola interna rimossa per una maggiore chiarezza visiva

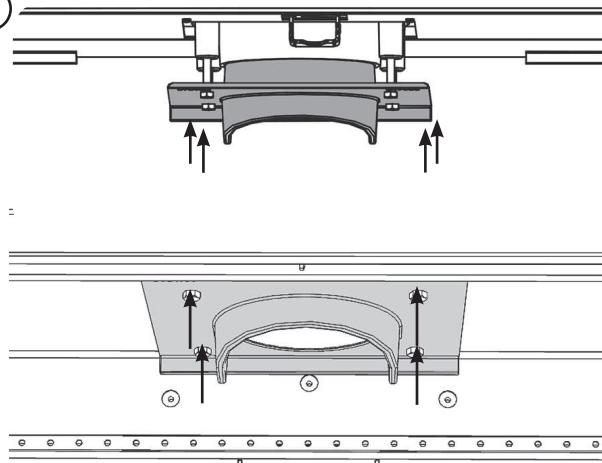

MATTONCINI REFRATTARI DELLA CAMERA DI COMBUSTIONE

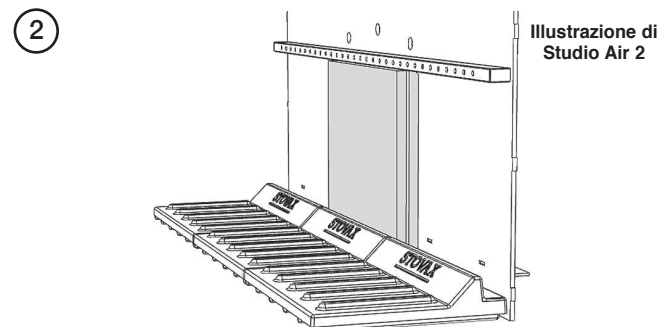
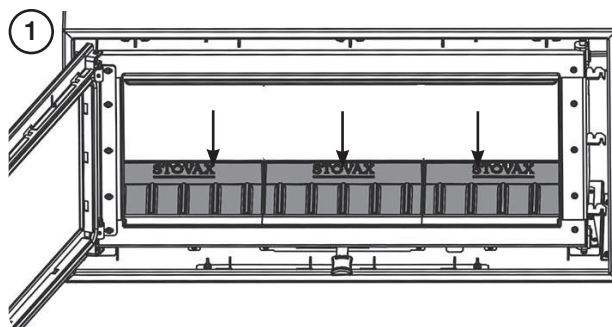

MONTAGGIO DELLA CORNICE DECORATIVA INTERNA

Illustrazione di Studio Air 2

Parte posteriore dell'apparecchio
L'illustrazione mostra solo i mattoni refrattari posteriori

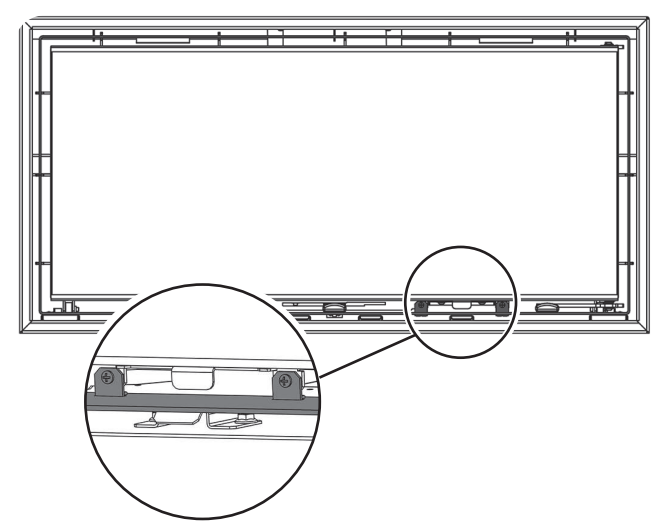
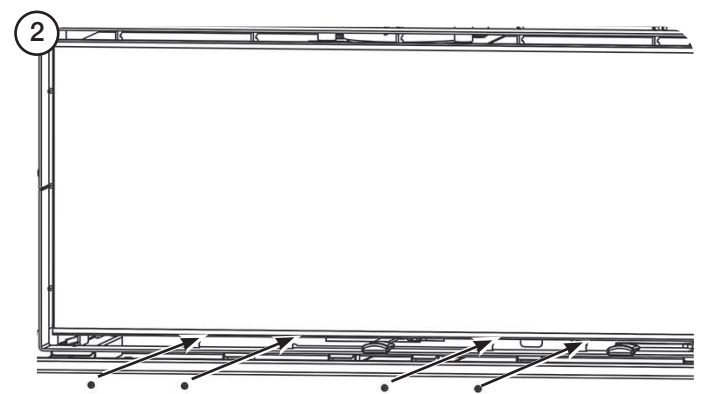
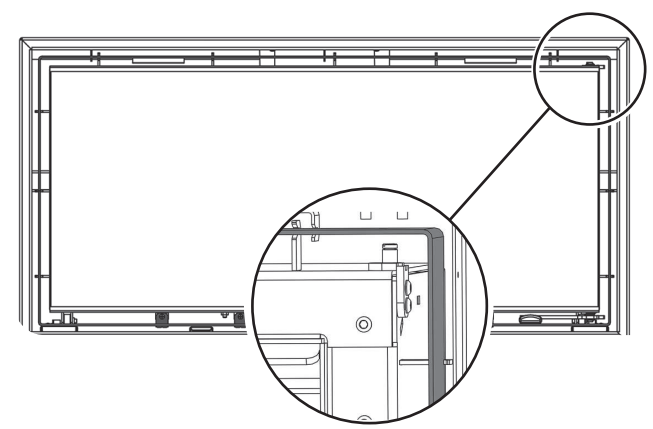
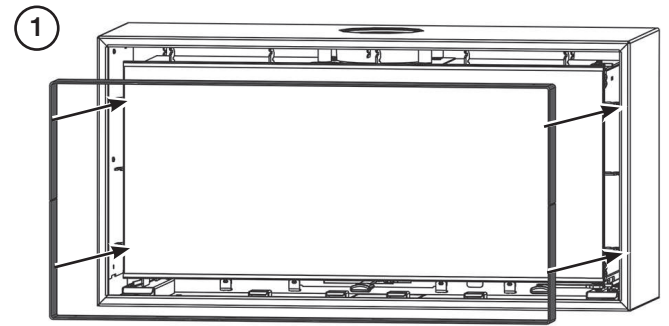
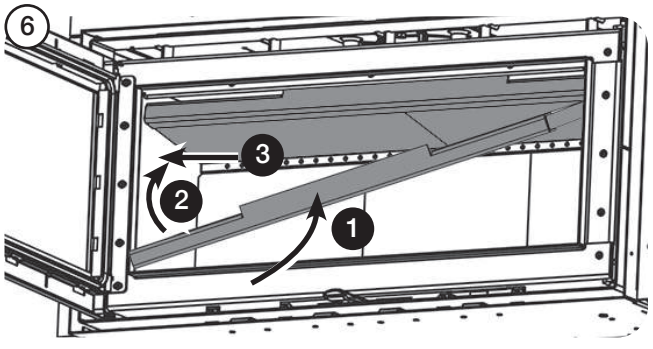
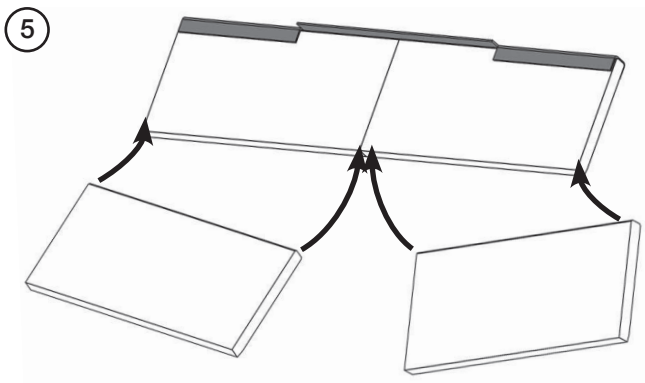
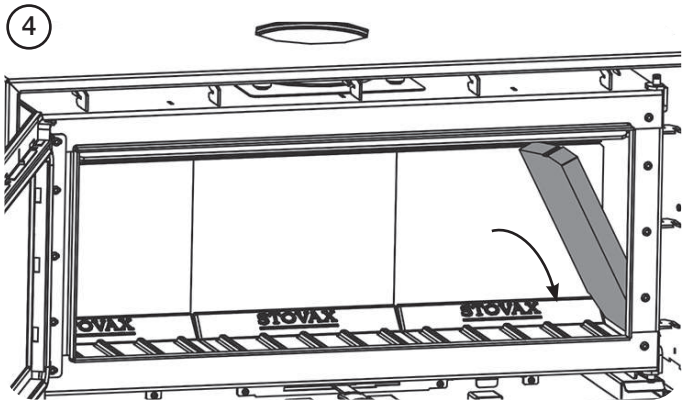
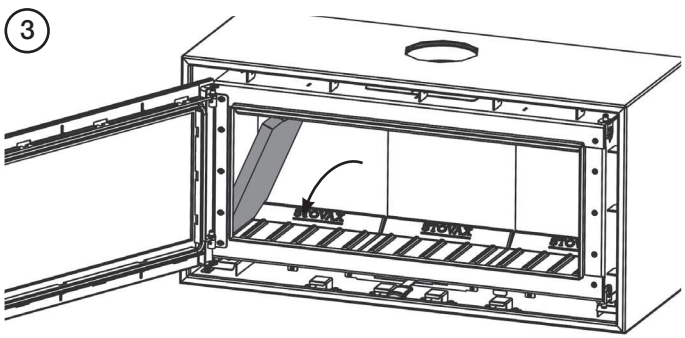
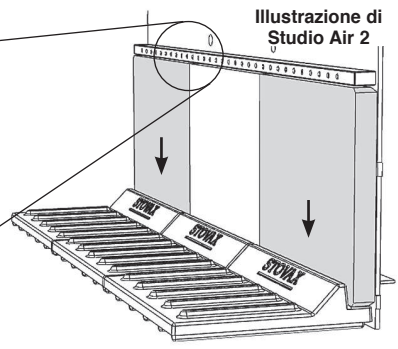

INVERSIONE DELLO SPORTELLO

i Per modificare l'orientamento dello sportello, prima di iniziare la procedura occorre acquistare da Stovax un gancio per maniglia di sportello reversibile N° di serie 326-929. Conservare il gancio originale per riportare lo sportello nella sua posizione iniziale.

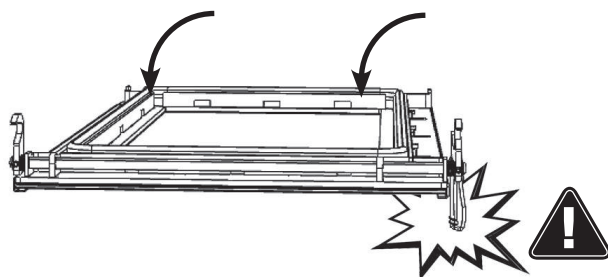
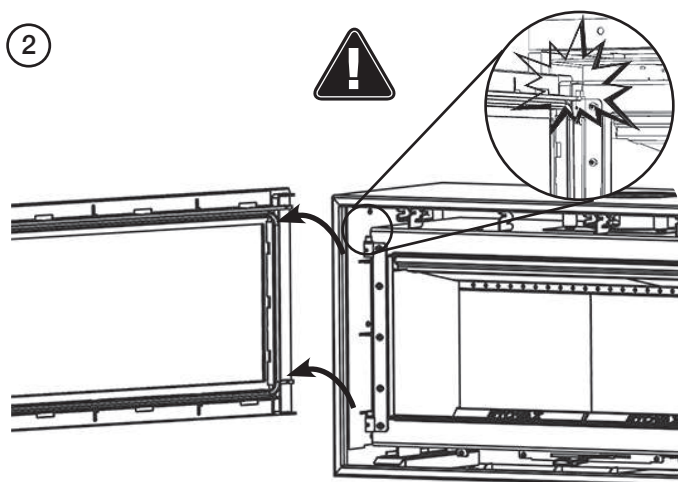
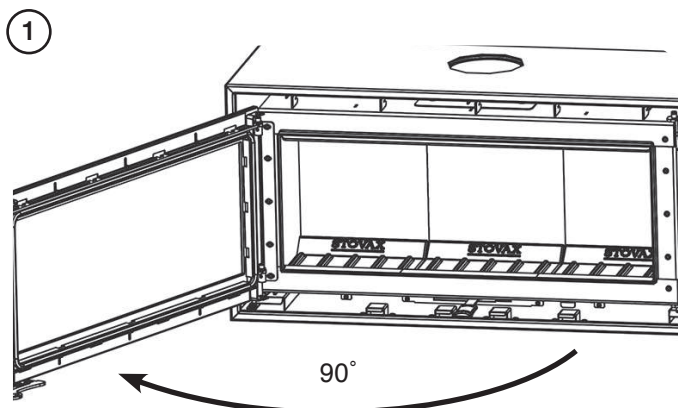

i Dopo aver invertito lo sportello potrebbe essere necessario regolare le cerniere e i fermi dello sportello per garantire che si chiuda in maniera corretta e sicura. Lo sportello deve essere orizzontale/livellato con la parte superiore della scatola interna e il fermo dello sportello deve inserirsi correttamente. Vedere Manutenzione e assistenza.

Sistema di cardini dello sportello

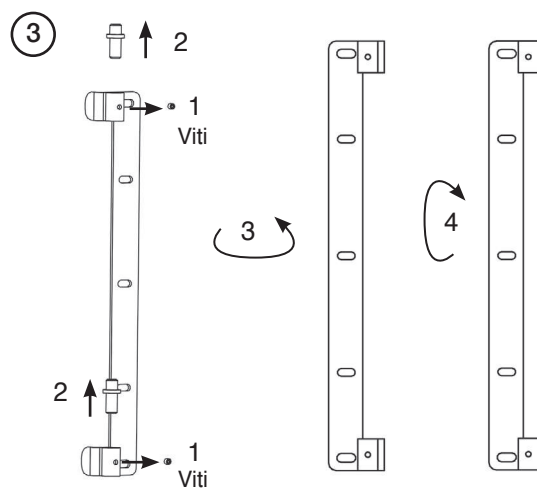
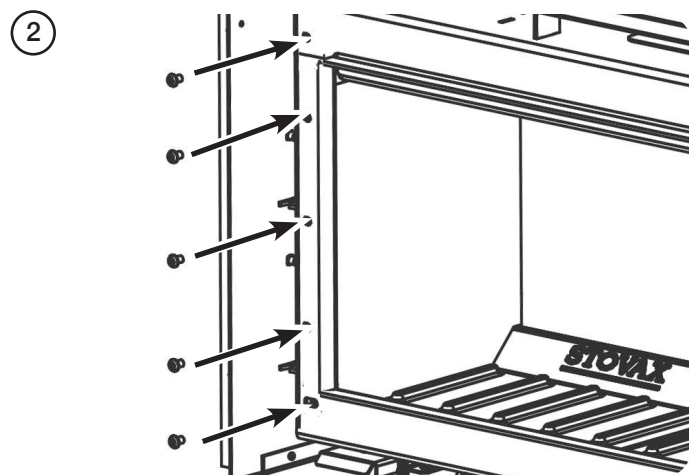
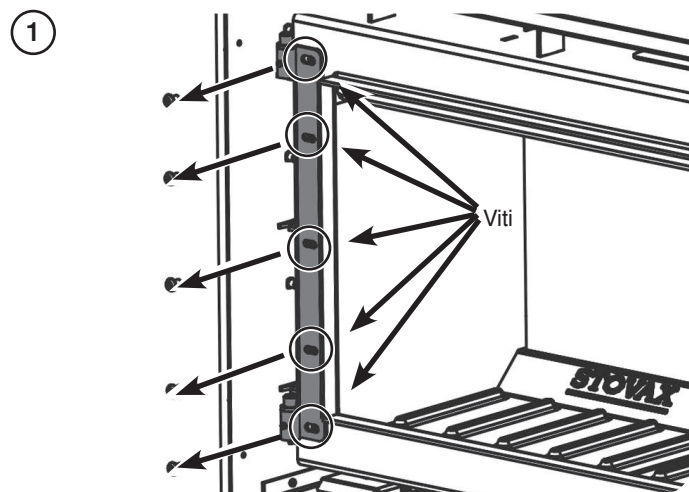

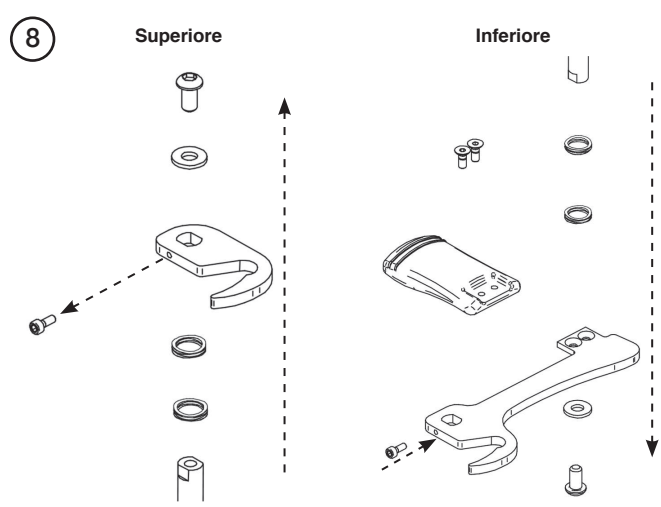
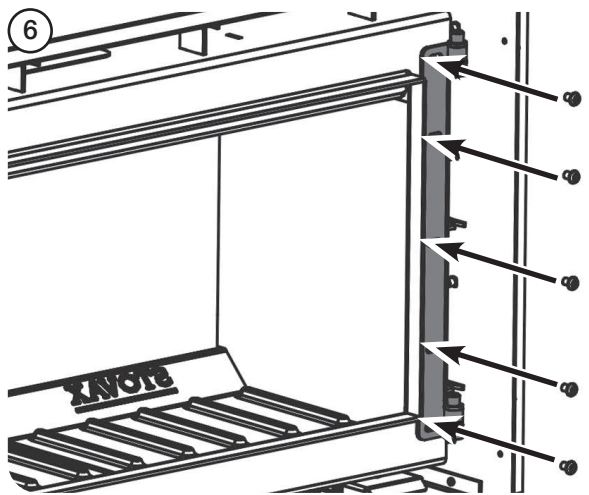
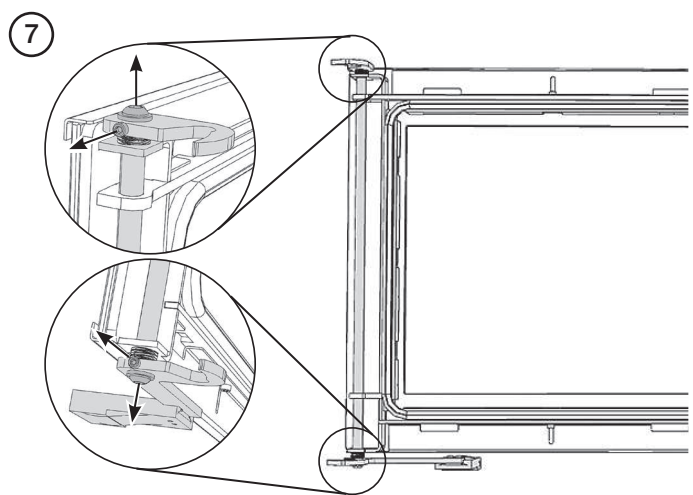
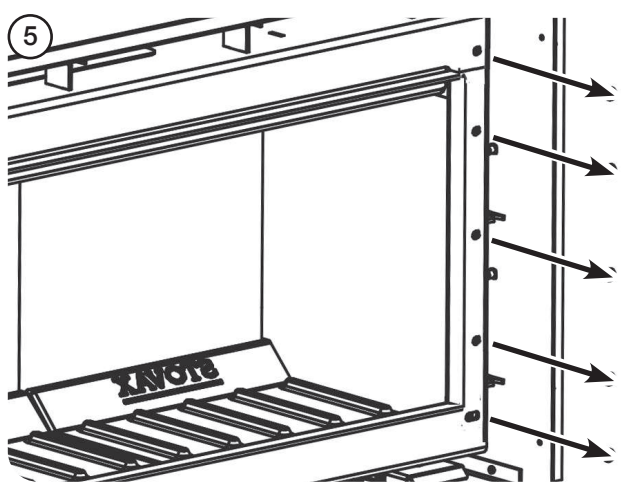
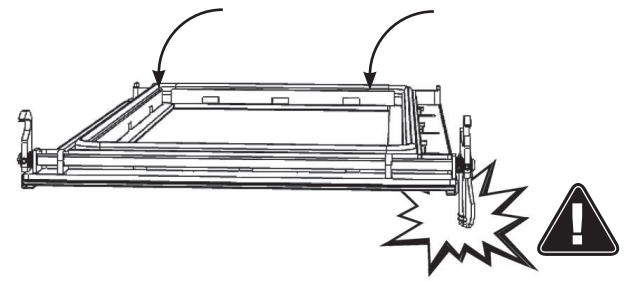
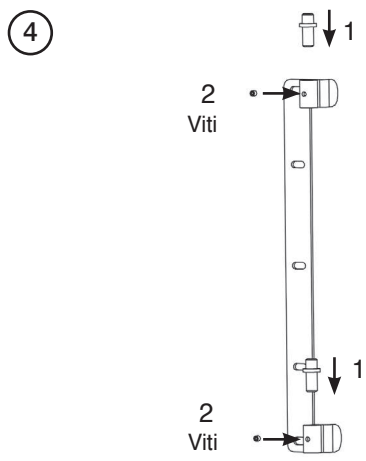

i Collocare lo sportello rivolto verso il basso su una superficie piana e morbida per proteggere le parti verniciate e il vetro.

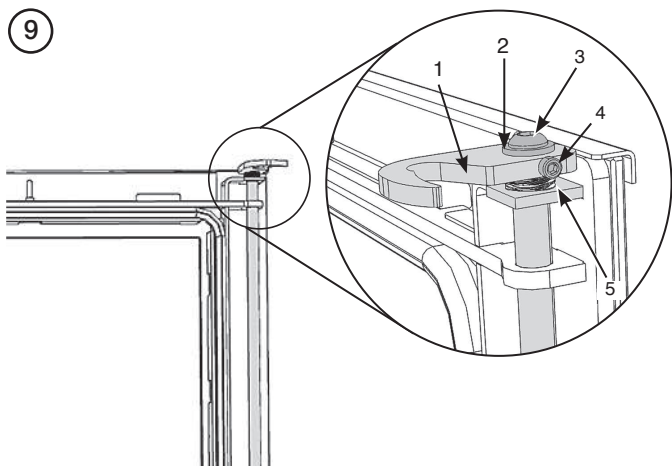

1. Fermo superiore
2. Rondella
3. Vite Grande
4. Vite Piccola
5. 2x Molle

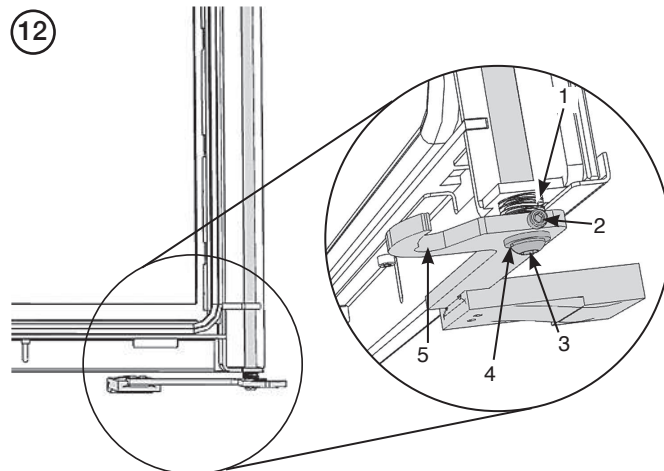

1. 2x Molle
2. Vite Piccola
3. Vite Grande
4. Rondella
5. Fermo inferiore

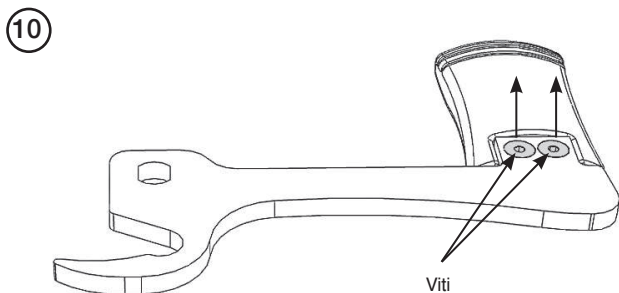

i Per modificare l'orientamento dello sportello, prima di iniziare la procedura occorre acquistare da Stovax un gancio per maniglia di sportello reversibile N° di serie 326-929. Conservare il gancio originale per riportare lo sportello nella sua posizione iniziale.

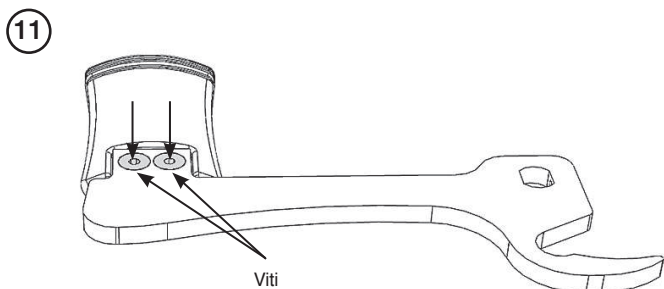

Fermi dello sportello

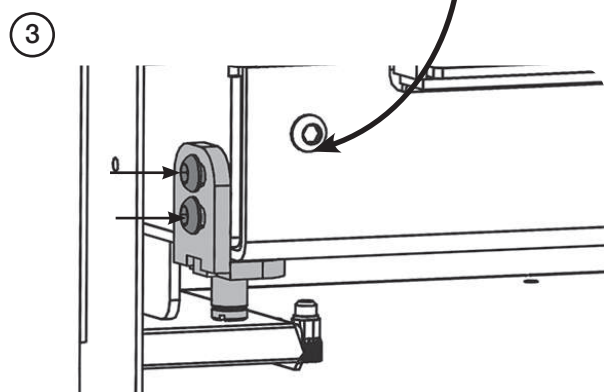
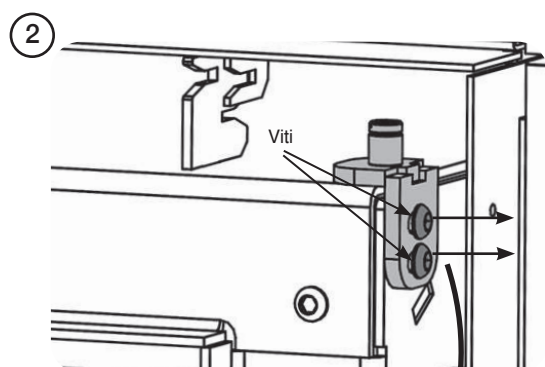
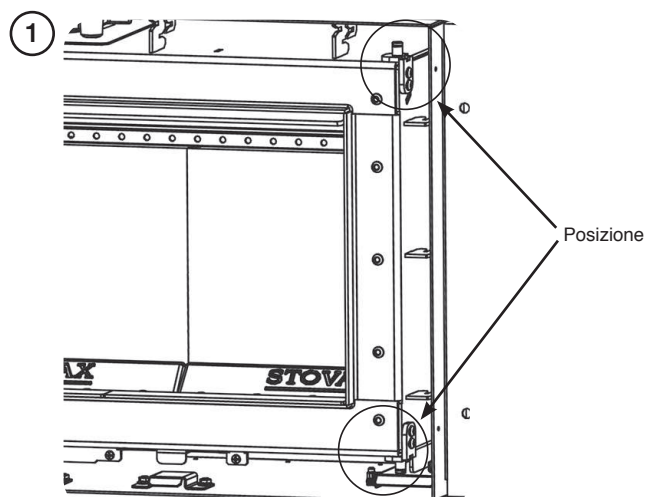

i Chiudere i fori sul lato opposto della scatola con le viti precedentemente rimosse.

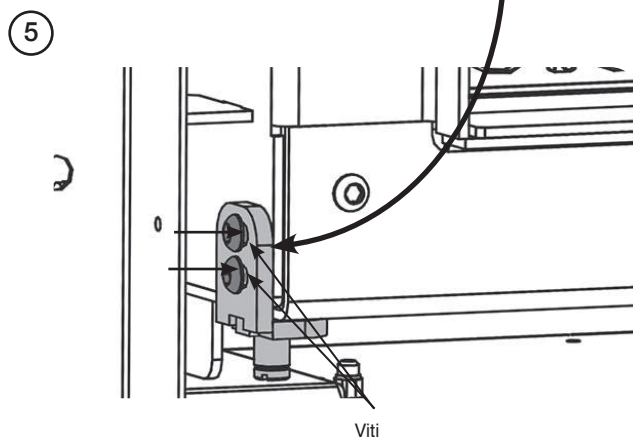
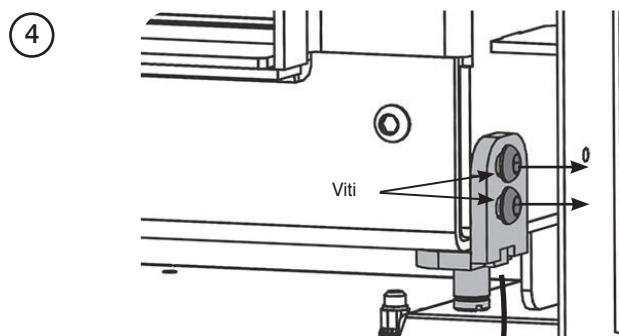

i Chiudere i fori sul lato opposto della scatola con le viti precedentemente rimosse.

Rimontare lo sportello.

i Dopo aver invertito lo sportello potrebbe essere necessario regolare le cerniere e i fermi dello sportello per garantire che si chiuda in maniera corretta e sicura. Lo sportello deve essere orizzontale/livellato con la parte superiore della scatola interna e il fermo dello sportello deve inserirsi correttamente. Vedere Manutenzione e assistenza.

MESSA A PUNTO

Per la messa a punto:

- Sostituire i componenti interni.
- Controllare l'allineamento dello sportello e il funzionamento del fermo, regolare se necessario, consultare la sezione di Manutenzione E Interventi Di Assistenza.
- Controllare l'integrità delle guarnizioni, dei pezzi di fusione e delle giunture.
- Controllare il funzionamento dei comandi dell'aria.

Ora eseguire il test finale di tiraggio del fumo:

- Per prima cosa, riscaldare la canna fumaria con la fiamma ossidrica o simile per circa 10 minuti.
- Posizionare un pellet al centro dei mattoni di base, con i comandi dell'aria aperti.
- Chiudere lo sportello.
Adesso il fumo dovrebbe essere aspirato nella canna fumaria e lo si dovrebbe vedere uscire dal comignolo.
- Completare il test con tutte le porte e le finestre chiuse nell'ambiente in cui si trova l'apparecchio.
- Se nei vani adiacenti esistono ventole di estrazione, il test deve essere ripetuto con le ventole operanti al massimo e con le porte di collegamento aperte.
- Controllare l'effetto dei ventilatori a soffitto durante il test.

Se si verificano perdite eccessive permettere all'apparecchio di raffreddarsi e ricontrrollare il sistema della canna fumaria e la ventilazione.

Infine:

- Spiegare all'utente il funzionamento sicuro dell'apparecchio, l'utilizzo dei comandi e l'importanza di utilizzare solamente i combustibili adatti.
- Verificare l'installazione dell'allarme di monossido di carbonio e spiegarne all'utente l'importanza e il funzionamento facendo riferimento alla sezione Attenzione delle Istruzioni dell'utente.
- Spiegare le necessità di pulizia e manutenzione di routine.
- Spiegare la necessità di utilizzare un parafuoco adatto quando bambini, anziani o invalidi sono vicini all'apparecchio.
- Registrare le informazioni sul rivenditore/fornitore e sull'installatore nelle istruzioni.
- Registrare il numero di serie alla pagina 3 delle istruzioni.

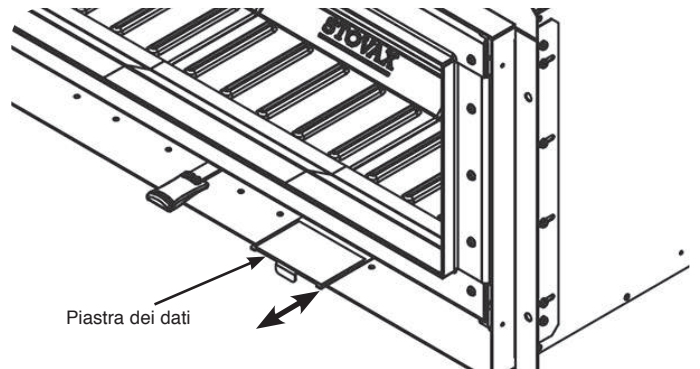

Questo numero è necessario per l'ordinazione delle parti di ricambio e per le richieste di intervento in garanzia.

- Consegnare una copia delle istruzioni al cliente.

MANUTENZIONE E INTERVENTI DI ASSISTENZA

Per l'elenco completo delle parti di ricambio e degli accessori contattare il proprio rivenditore Stovax o visitare: www.stovaxspares.co.uk.

Prima dell'inizio della stagione fredda, ispezionare e pulire l'apparecchio come segue:

- Far raffreddare l'apparecchio.
- Rimuovere tutte le seguenti parti interne; deflettori e mattoni refrattari.
Maneggiare con cura i mattoni refrattari, in quanto possono diventare fragili con l'uso.
- Se necessario, a questo punto spazzare l'apparecchio.
- Rimuovere con l'aspirapolvere le ceneri e i detriti rimanenti dall'interno dell'apparecchio.
Stovax offre un filtro/accessorio di raccolta per l'aspirapolvere, per proteggerlo dalle ceneri calde.
- Controllare che i componenti non siano danneggiati. Sostituire i componenti danneggiati utilizzando ricambi originali Stovax.
- Controllare e pulire i mattoni refrattari con una spazzola morbida.
L'utilizzo può comportare danni alle superfici. La durata dei mattoni dipende dal tipo di combustibile bruciato e dal livello di utilizzo.
I mattoni danneggiati devono essere sostituiti quanto prima possibile.
- Reinscrivere le parti interne ripulite.
- **Utilizzare Stovax Glass Cleaner (Stovax N. 4103) la cui formulazione è ideale per questa applicazione.**
Non utilizzare detergenti abrasivi per rimuovere il catrame o i depositi di fuliggine dal vetro.
- Installare una nuova guarnizione dello sportello.
- Oliare leggermente il meccanismo della presa dello sportello e i perni dei cardini. Evitare che l'olio entri nelle guarnizioni e sul vetro dello sportello.
- Per aggiornare dipinto finisce un ritocco spray è disponibile.
Contattate il vostro rivenditore Stovax citando il numero di serie riportato sul distintivo dati dell'apparecchio.

Utilizzare le parti di ricambio Stovax originali per mantenere l'apparecchio in uno stato di funzionamento sicuro ed efficiente. Questo è un elenco dei prodotti di manutenzione che potrebbe essere necessario utilizzare:

I prodotti utili per la pulizia e la manutenzione di Studio Air sono disponibili online sul sito www.stovax.com o presso il proprio rivenditore Stovax locale. Insieme a una manutenzione regolare e all'uso di combustibili corretti, questi prodotti manterranno l'apparecchio nelle migliori condizioni possibili.

Per ulteriori informazioni sui prodotti del gruppo Stovax, visitare il nostro sito Web all'indirizzo www.stovax.com

Primo utilizzo dell'apparecchiatura bruciare a bassa potenza durante il primo giorno di utilizzo. Questo permette alle guarnizioni, alle colle di fissaggio e alla vernice di indurirsi completamente.

Durante questo periodo potrebbe emettere cattivi odori. Aerare bene l'ambiente per evitare che i fumi si accumulino.

Il rivenditore Stovax può eseguire interventi di assistenza e manutenzione.

i **IMPORTANTE: Stovax fornisce dei guanti speciali per proteggere gli utilizzatori da calore e bordi taglienti quando si utilizza l'apparecchio. Per ragioni di sicurezza è bene indossare sempre i guanti quando si aprono, azionano, alimentano o manipolano parti metalliche.**

ATTIVITÀ	NOME PRODOTTO	NO.
Prevenzione dell'accumulo di creosoto nella canna fumaria	Protezione (15 bustine)	7002
	Protezione (vaschetta da 1 kg)	7025
Impermeabilizzazione delle giunture della canna fumaria	Cemento refrattario (vaschetta da 500 g)	2024
	Cemento refrattario (cartuccia da 600 g)	2021
Riverniciatura	Vernice per ritocco (aerosol da 150 ml)	2056
Protezione delle mani	Guanti in pelle resistenti al calore	4008 4027 - Lungo
Colla termosaldante	(bottiglia da 50 ml)	5037
Pulizia del vetro	Stovax Vetro Pulito	4103
Cenere Pulita	Accessorio per l'aspirapolvere	2091M

INSTALLAZIONE DI UNA NUOVA GUARNIZIONE DELLO SPORTELLO

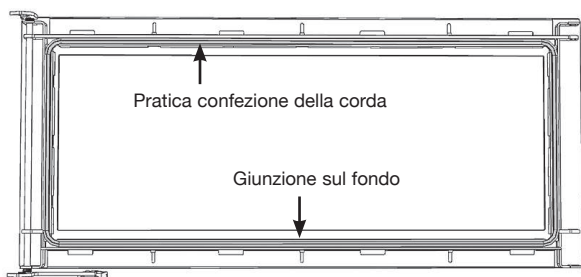
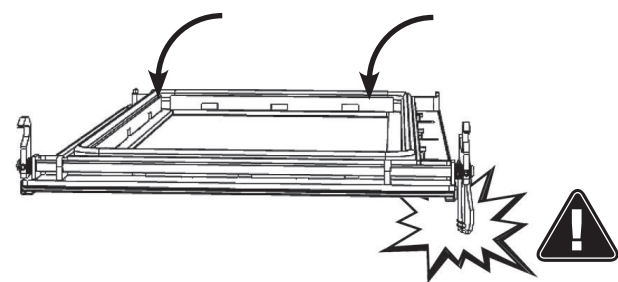
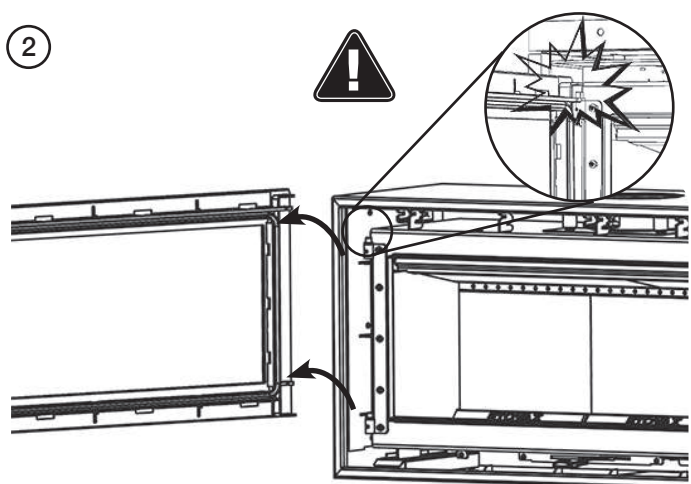
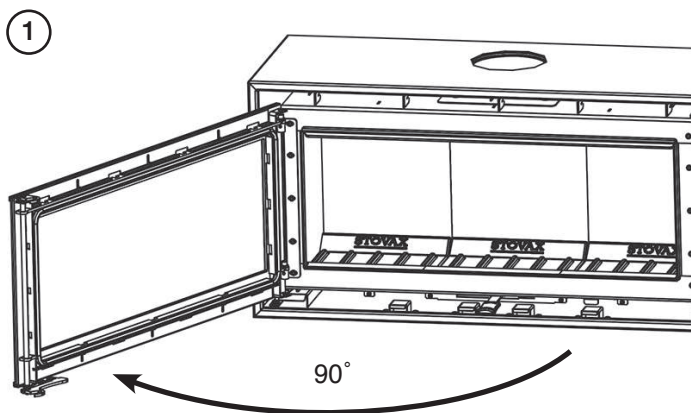

Per mantenere l'utilizzo sicuro dell'apparecchio, è possibile dover sostituire un cavo di chiusura dello sportello danneggiato o consumato. Per completare questa operazione, rimuovere lo sportello.

Rimuovere il vecchio cavo e grattare la colla vecchia dalla scanalatura di posizionamento. Pulire la scanalatura di posizionamento con un panno asciutto pulito per rimuovere tutta la polvere vecchia e i detriti.

Spremere una noce abbondante di colla Stovax Thermic Seal fresca nella scanalatura di posizionamento del cavo.

Premere il nuovo cavo Stovax nella scanalatura di posizionamento, collocando la giuntura a metà del bordo superiore dello sportello utilizzando l'adesivo fornito per le estremità.

Reinserire lo sportello e chiuderlo per applicare pressione sul nuovo cavo:

Lasciare l'apparecchio chiuso per almeno 12 ore prima di accendere l'apparecchio e utilizzare a bassa potenza per circa un giorno.

L'utilizzo dell'apparecchio con una guarnizione dello sportello danneggiata può causare la fuoriuscita di esalazioni pericolose nella camera, oppure portare ad un surriscaldamento dell'apparecchio, con conseguenti danni.

REGOLAZIONE DEI CARDINI DELLO SPORTELLO

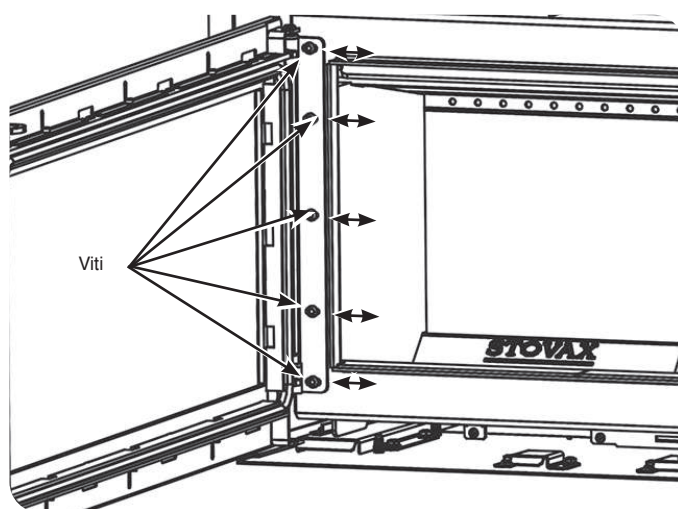

Per conservare l'utilizzo sicuro dell'apparecchio, può essere necessario regolare i cardini dello sportello per garantire la chiusura corretta e sicura dello sportello. Lo sportello deve essere orizzontale/allineato con la parte superiore della confezione interna e il fermo dello sportello si deve inserire correttamente.

La regolazione è possibile agendo sulle cerniere nella scatola interna.

Aprile lo sportello per accedere.

Blocco cardini sulla confezione interna

Utilizzando una chiave da 10 mm A/F allentare leggermente i dadi di fissaggio nella stufa.

Ciò assicurerà una regolazione orizzontale e potrà richiedere un approccio a tentativi per trovare la posizione corretta.

Lo sportello deve essere in piano.

REGOLAZIONE DELLA PRESA DELLO SPORTELLO

Per conservare l'utilizzo sicuro dell'apparecchio, può essere necessario regolare la presa dello sportello per garantire la chiusura corretta e sicura dello sportello. Se i cardini dello sportello sono stati regolati, la presa dello sportello può necessitare di regolazione.

Gli schemi mostrano la regolazione di uno sportello con cerniere a sinistra. Il metodo è lo stesso anche in caso di inversione dello sportello.

I fermi sono posizionati nella parte superiore e inferiore del lato aperto dello sportello.

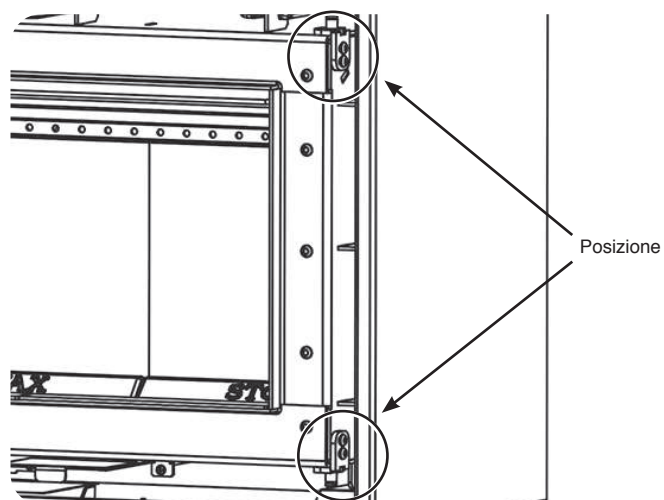

Fermo dello sportello superiore

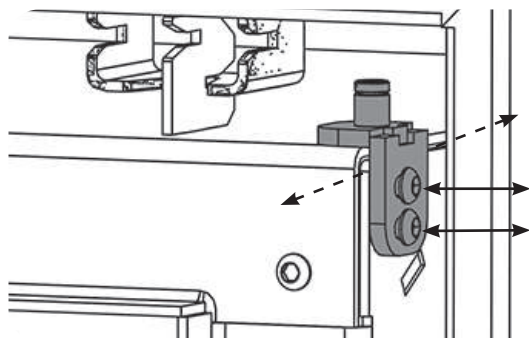

Fermo dello sportello inferiore

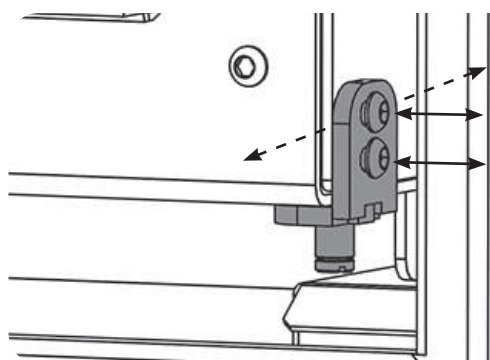

Allentando o serrando la vite M6 e i dadi sul fermo-presa, è possibile muovere la presa verso l'interno o l'esterno dello sportello, consentendo un miglior appiglio del gancio sui rulli dello sportello.

Non rimuovere completamente la vite o i dadi.

ESEGUIRE UN TEST DELLA CARTA

Per eseguire un test con la carta, chiudere un pezzo di carta nei bordi dello sportello per vedere come la tenuta della corda riesce ad impedire all'aria di entrare nell'apparecchio. Se è facile tirare via la carta, la guarnizione non è sufficiente e la corda deve essere sostituita.

Ripetere questo passo su tutti i bordi della stufa.

SCHEDA DEL PRODOTTO: RICHIESTA DI INFORMAZIONI PER RISCALDATORE A COMBUSTIBILE SOLIDO PER AMBIENTI

Modello	Studio Air 1	Studio Air 2
Classe di efficienza diretta	A+	A
Emissione di calore diretta (kW)	6.2	8.2
Emissione indiretta (kW)	-	-
Indice di efficienza energetica (EEI)	109	105
Efficienza energetica utile a emissione di calore nominale	81.4%	78.5%
Precauzioni di sicurezza	Installare, utilizzare ed effettuare la manutenzione dell'apparecchio seguendo le istruzioni dei produttori	

INFORMAZIONI SUL MATERIALE DEL PRODOTTO

Le sostanze, i preparati o i componenti seguenti devono essere smaltiti o recuperati separatamente rispetto ad altri RAEE in conformità all'articolo 4 della direttiva del Consiglio dell'UE 75/442/CEE.

Metallo	Acciaio	Possono essere conferiti a un centro di riciclaggio locale per il loro recupero al fine di ridurre la quantità di rifiuti portati in discarica.
	Ghisa	
Vetro		Possono essere conferiti a un centro di riciclaggio locale per il loro recupero al fine di ridurre la quantità di rifiuti portati in discarica.
Rivestimenti in vermiculite		Materiale non pericoloso. La vermiculite può essere frantumata e utilizzata per il substrato delle aiuole e la cenere destinata al compostaggio o portata presso un centro di riciclaggio locale per il suo recupero al fine di ridurre la quantità di rifiuti conferiti in discarica.
Guarnizioni		Le guarnizioni sono realizzate in fibra ceramica refrattaria (FCR), un materiale spesso utilizzato per questa applicazione. Non è necessario indossare indumenti di protezione quando si manipolano questi articoli ma è consigliato attenersi alle normali norme igieniche che prevedono il divieto di fumare, mangiare o bere nell'area di lavoro e di lavarsi sempre le mani prima di mangiare o bere. Durante gli interventi di assistenza sull'apparecchio si consiglia di non smontare i componenti sostituiti ma di sigillarli all'interno di sacchetti di polietilene resistenti e di contrassegnarli come rifiuti FCR. I rifiuti FCR sono classificati come rifiuti pericolosi non reattivi e stabili e possono essere smaltiti in una discarica autorizzata.
Componenti elettrici	(kit di ventole ecc. se applicabile)	Smaltire presso un centro di riciclaggio locale in conformità alla direttiva RAEE.

SPARE PARTS/ LISTE DES PIÈCES DE RECHANGE/ ELENCO DELLE PARTI DI RICAMBIO

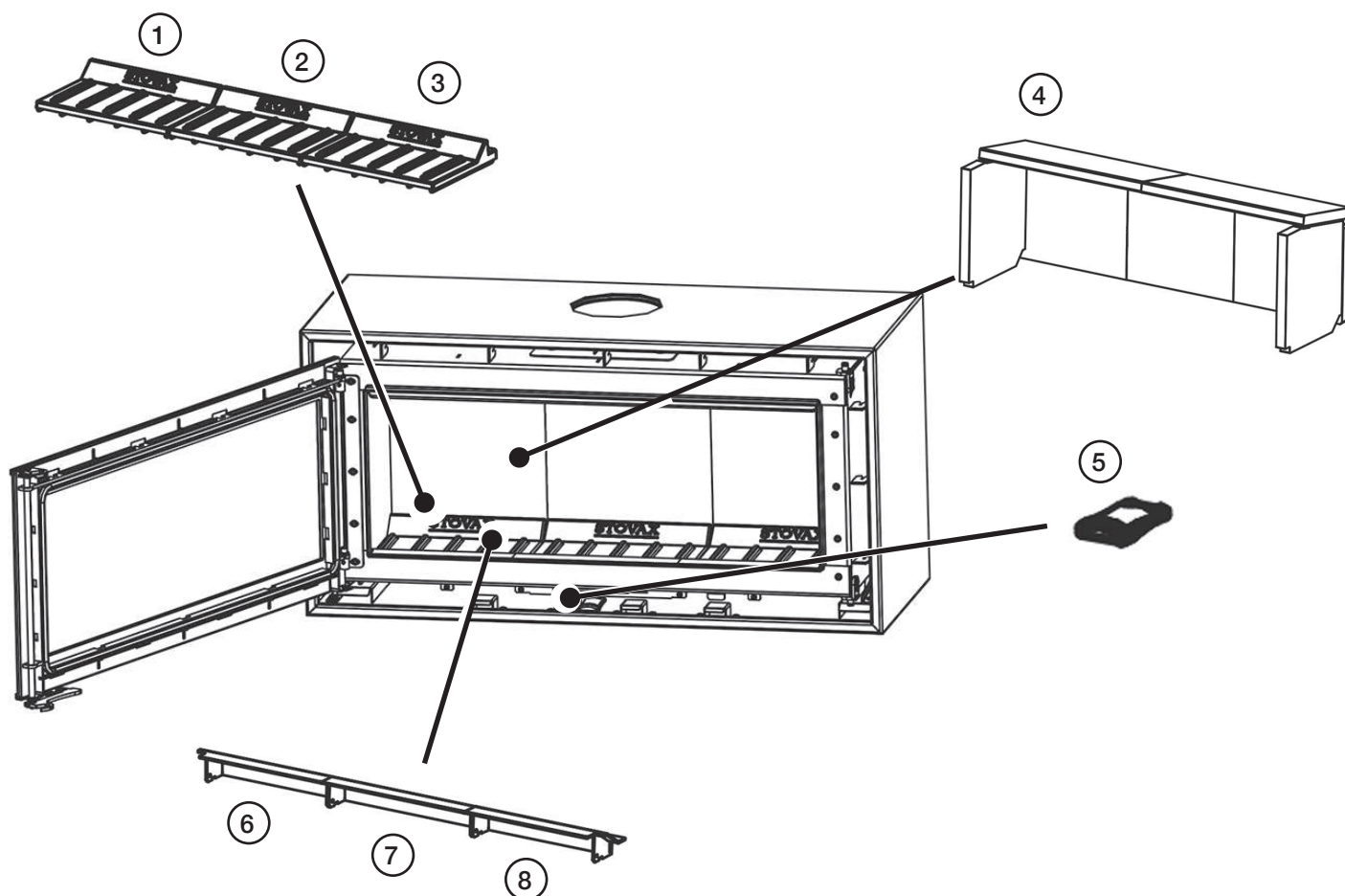

REF.	GB DESCRIPTION	FR DESCRIPTION	IT DESCRIZIONE	CODE/ CODICE	
				STUDIO 1	STUDIO 2
1	Base Brick - Left	Plaque sol foyer gauche	Mattone per la base - Sinistra	CA7898	CA7897
2	Base Brick - Center	Plaque sol foyer Cental	Mattone per la base - Centro	CA7897	CA7897
3	Base Brick - Right	Plaque sol foyer droite	Mattone per la base - Destra	CA7898	CA7897
4	Upper Brick Set	Ensemble de vermiculites	Set di mattoni per la parte superiore	MEC11430	MEC11407
5	Handle	Poignée	Maniglia	CA7919	CA7919
6	Ashlip - Left	Maintien cendres gauche	Guarnizione paracenera - Sinistra	MEC11915	MEC11932
7	Ashlip - Center	Maintien cendres centre	Guarnizione paracenera - Centro	MEC11914	MEC11914
8	Ashlip - Right	Maintien cendres droit	Guarnizione paracenera - Destra	MEC11916	MEC11933

SPARE PARTS/ LISTE DES PIÈCES DE RECHANGE/ ELENCO DELLE PARTI DI RICAMBIO

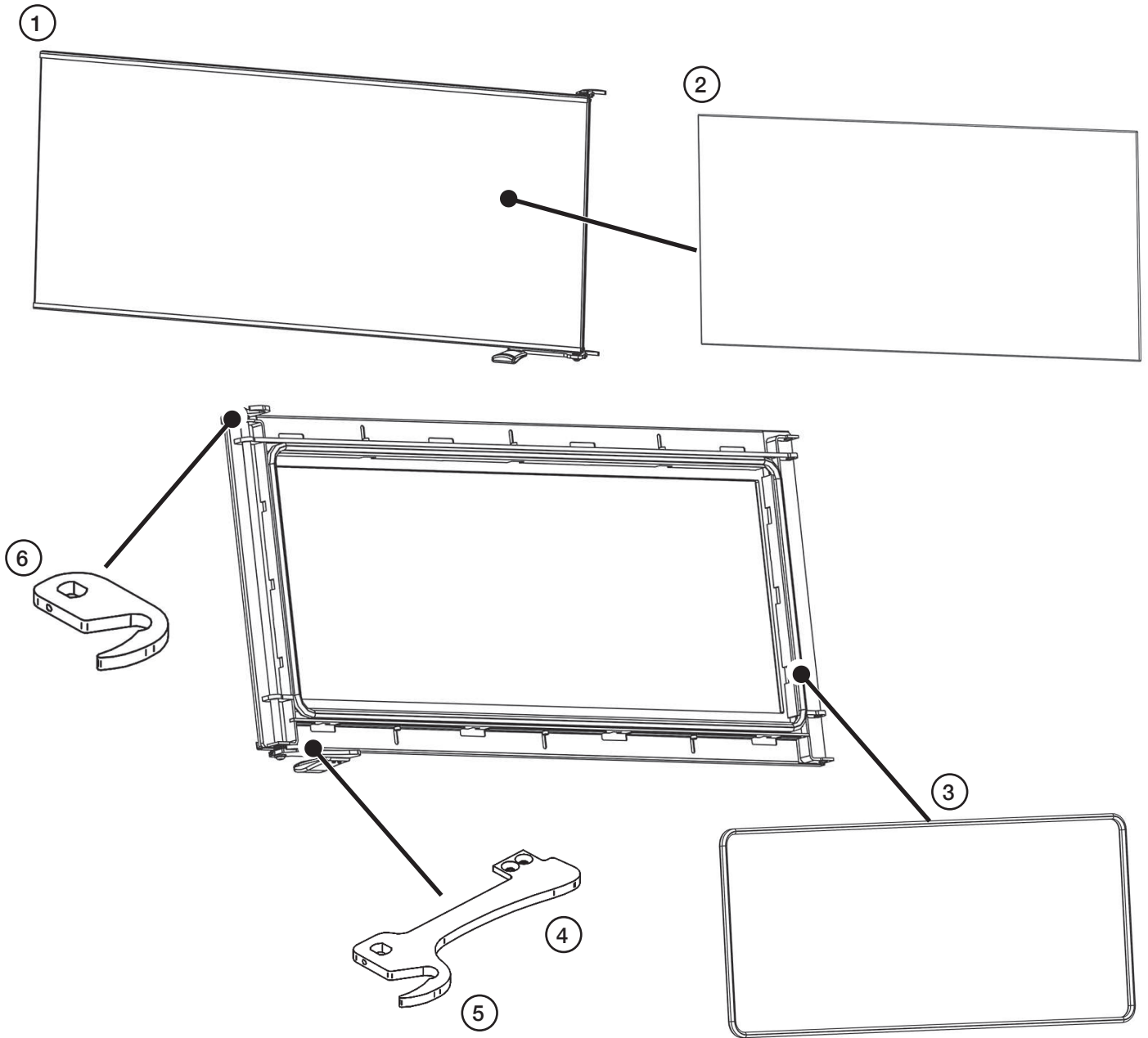

REF.	GB DESCRIPTION	FR DESCRIPTION	IT DESCRIZIONE	CODE/ CODICE	
				STUDIO 1	STUDIO 2
1	Complete Door Assembly	Assemblage de porte	Gruppo sportello completo	MEC11976	MEC11978
2	Door Glass	Joint de porte	Vetro dello sportello	CE8384	CE8375
3	RopeSeal	Tresse d'étanchéité	Guarnizione	CE8383	CE8381
4	Door Handle Latch	Loquet de porte	Fermo per la maniglia dello sportello	ME602440	
5	Reversible Door Handle Latch	Loquet de porte inversée	Fermo per la maniglia dello sportello invertibile	ME602328	
6	Top Catch	Loquet de porte supérieur	Fermo superiore	ME602439	

**SERVICE RECORDS/ FICHES DE MAINTENANCE/
REGISTRI DEGLI INTERVENTI DI ASSISTENZA****SERVICE/ ENTRETIEN/ INTERVENTO DI ASSISTENZA**

Date/Data:.....
Next/ Prochain /Prossimo:.....
Signed:.....
Dealer's Stamp/ Distributeur /Rivenditor
(HETAS Registration Number)

SERVICE/ ENTRETIEN/ INTERVENTO DI ASSISTENZA

Date/Data:.....
Next/ Prochain /Prossimo:.....
Signed:.....
Dealer's Stamp/ Distributeur /Rivenditor
(HETAS Registration Number)

SERVICE/ ENTRETIEN/ INTERVENTO DI ASSISTENZA

Date/Data:.....
Next/ Prochain /Prossimo:.....
Signed:.....
Dealer's Stamp/ Distributeur /Rivenditor
(HETAS Registration Number)

SERVICE/ ENTRETIEN/ INTERVENTO DI ASSISTENZA

Date/Data:.....
Next/ Prochain /Prossimo:.....
Signed:.....
Dealer's Stamp/ Distributeur /Rivenditor
(HETAS Registration Number)

SERVICE/ ENTRETIEN/ INTERVENTO DI ASSISTENZA

Date/Data:.....
Next/ Prochain /Prossimo:.....
Signed:.....
Dealer's Stamp/ Distributeur /Rivenditor
(HETAS Registration Number)

SERVICE/ ENTRETIEN/ INTERVENTO DI ASSISTENZA

Date/Data:.....
Next/ Prochain /Prossimo:.....
Signed:.....
Dealer's Stamp/ Distributeur /Rivenditor
(HETAS Registration Number)

SERVICE/ ENTRETIEN/ INTERVENTO DI ASSISTENZA

Date/Data:.....
Next/ Prochain /Prossimo:.....
Signed:.....
Dealer's Stamp/ Distributeur /Rivenditor
(HETAS Registration Number)

SERVICE/ ENTRETIEN/ INTERVENTO DI ASSISTENZA

Date/Data:.....
Next/ Prochain /Prossimo:.....
Signed:.....
Dealer's Stamp/ Distributeur /Rivenditor
(HETAS Registration Number)

SERVICE/ ENTRETIEN/ INTERVENTO DI ASSISTENZA

Date/Data:.....
Next/ Prochain /Prossimo:.....
Signed:.....
Dealer's Stamp/ Distributeur /Rivenditor
(HETAS Registration Number)

SERVICE/ ENTRETIEN/ INTERVENTO DI ASSISTENZA

Date/Data:.....
Next/ Prochain /Prossimo:.....
Signed:.....
Dealer's Stamp/ Distributeur /Rivenditor
(HETAS Registration Number)

FOR ENQUIRIES IN THE U.K (EXCLUDING NI):

Stovax Ltd, Falcon Road, Sowton Industrial Estate, Exeter, Devon, England EX2 7LF

Tel: (01392) 474011 E-mail: info@stovax.com www.stovax.com

FOR ENQUIRIES IN EUROPE (INCLUDING NI):

Stovax Heating Group (NI) Ltd (Comp reg NI675194), 40 Linenhall Street, Belfast, BT2

8BA DX 400 NR Belfast Tel: +44 (0)1392 261990 E-mail: northernireland@stovax.com



STOVAX



PM1637